IgH Ether**CAT**[®] Master 1.6.0 Documentation

Dipl.-Ing. (FH) Florian Pose, fp@igh.de
Ingenieurgesellschaft **IGH**

Essen, June 7, 2024
Revision 1.6.0-4-gbc945f69

Contents

Conventions	x
1 The IgH EtherCAT Master	1
1.1 Feature Summary	1
1.2 License	3
2 Architecture	5
2.1 Master Module	7
2.2 Master Phases	9
2.3 Process Data	9
3 Application Interface	13
3.1 Master Configuration	13
3.1.1 Slave Configuration	13
3.2 Cyclic Operation	15
3.3 VoE Handlers	17
3.4 Concurrent Master Access	17
3.5 Distributed Clocks	19
3.6 Application Interface Header	22
3.7 Userspace Application Example	70
4 Ethernet Devices	77
4.1 Network Driver Basics	77
4.2 Native EtherCAT Device Drivers	79
4.3 Generic EtherCAT Device Driver	82
4.4 Providing Ethernet Devices	83
4.5 Redundancy	83
4.6 EtherCAT Device Interface	83
4.7 Patching Native Network Drivers	84
5 State Machines	85
5.1 State Machine Theory	86
5.2 The Master's State Model	88
5.3 The Master State Machine	91
5.4 The Slave Scan State Machine	91
5.5 The Slave Configuration State Machine	94
5.6 The State Change State Machine	96

5.7	The SII State Machine	97
5.8	The PDO State Machines	98
6	Mailbox Protocol Implementations	103
6.1	Ethernet over EtherCAT (EoE)	103
6.1.1	EoE Interface Configuration	106
6.2	CANopen over EtherCAT (CoE)	107
6.3	Vendor specific over EtherCAT (VoE)	109
6.4	Servo Profile over EtherCAT (SoE)	109
7	Userspace Interfaces	111
7.1	Command-line Tool	111
7.1.1	Character Devices	111
7.1.2	Setting Alias Addresses	112
7.1.3	Displaying the Bus Configuration	112
7.1.4	Display CRC Error Counters	113
7.1.5	Output PDO information in C Language	113
7.1.6	Displaying Process Data	114
7.1.7	Setting a Master's Debug Level	114
7.1.8	Configured Domains	114
7.1.9	SDO Access	115
7.1.10	EoE Statistics	117
7.1.11	File-Access over EtherCAT	117
7.1.12	Creating Topology Graphs	118
7.1.13	Setting Ethernet-over-EtherCAT IP Parameters	118
7.1.14	Master and Ethernet Devices	119
7.1.15	Sync Managers, PDOs and PDO Entries	119
7.1.16	Register Access	120
7.1.17	Trigger a Bus Scan	121
7.1.18	SDO Dictionary	122
7.1.19	SII Access	122
7.1.20	Slaves on the Bus	124
7.1.21	SoE IDN Access	125
7.1.22	Requesting Application-Layer States	127
7.1.23	Displaying the Master Version	127
7.1.24	Generating Slave Description XML	127
7.2	Userspace Library	128
7.2.1	Using the Library	128
7.2.2	Implementation	129
7.2.3	Timing	129
7.3	RTDM Interface	130
7.4	System Integration	130
7.4.1	Init Script	130
7.4.2	Sysconfig File	131

7.4.3	Starting the Master as a Service	132
7.4.4	Integration with systemd	132
7.5	Debug Interfaces	134
8	Timing Aspects	135
8.1	Application Interface Profiling	135
8.2	Bus Cycle Measuring	136
9	Installation	139
9.1	Getting the Software	139
9.2	Building the Software	139
9.3	Building the Interface Documentation	141
9.4	Installing the Software	142
9.5	Automatic Device Node Creation	143
	Bibliography	145
	Glossary	147
	Index	149

List of Tables

3.1	Specifying a Slave Position	15
5.1	A typical state transition table	87
7.1	Application Interface Timing Comparison	129
8.1	Profiling of an Application Cycle on a 2.0 GHz Processor	135
9.1	Configuration options	140

List of Figures

2.1	Master Architecture	6
2.2	Multiple masters in one module	8
2.3	Master phases and transitions	10
2.4	FMMU Configuration	12
3.1	Master Configuration	14
3.2	Slave Configuration Attachment	16
3.3	Concurrent Master Access	18
3.4	Distributed Clocks	20
4.1	Interrupt Operation versus Interrupt-less Operation	81
5.1	A typical state transition diagram	87
5.2	Transition diagram of the master state machine	92
5.3	Transition diagram of the slave scan state machine	93
5.4	Transition diagram of the slave configuration state machine	95
5.5	Transition Diagram of the State Change State Machine	96
5.6	Transition Diagram of the SII State Machine	97
5.7	Transition Diagram of the PDO Reading State Machine	98
5.8	Transition Diagram of the PDO Entry Reading State Machine	99
5.9	Transition Diagram of the PDO Configuration State Machine	100
5.10	Transition Diagram of the PDO Entry Configuration State Machine	101
6.1	Transition Diagram of the EoE State Machine	105
6.2	Transition diagram of the CoE download state machine	108

Conventions

The following typographic conventions are used:

- *Italic face* is used for newly introduced terms and file names.
- **Typewriter face** is used for code examples and command line output.
- **Bold typewriter face** is used for user input in command lines.

Data values and addresses are usually specified as hexadecimal values. These are marked in the *C* programming language style with the prefix `0x` (example: `0x88A4`). Unless otherwise noted, address values are specified as byte addresses.

Function names are always printed with parentheses, but without parameters. So, if a function `ecrt_request_master()` has empty parentheses, this shall not imply that it has no parameters.

If shell commands have to be entered, this is marked by a dollar prompt:

\$

Further, if a shell command has to be entered as the superuser, the prompt is a mesh:

#

1 The IgH EtherCAT Master

This chapter covers some general information about the EtherCAT master.

1.1 Feature Summary

The list below gives a short summary of the master features.

- Designed as a kernel module for Linux from version 2.6 (or newer).
- Implemented according to IEC 61158-12 [2] [3].
- Comes with EtherCAT-capable native drivers for several common Ethernet chips, as well as a generic driver for all chips supported by the Linux kernel.
 - The native drivers operate the hardware without interrupts.
 - Native drivers for additional Ethernet hardware can easily be implemented using the common device interface (see [section 4.6](#)) provided by the master module.
 - For any other hardware, the generic driver can be used. It uses the lower layers of the Linux network stack.
- The master module supports multiple EtherCAT masters running in parallel.
- The master code supports any Linux realtime extension through its independent architecture.
 - RTAI [11] (including LXRT via RTDM), ADEOS, RT-Preempt [12], Xenomai (including RTDM), etc.
 - It runs well even without realtime extensions.
- Common “Application Interface” for applications, that want to use EtherCAT functionality (see [chapter 3](#)).
- *Domains* are introduced, to allow grouping of process data transfers with different slave groups and task periods.
 - Handling of multiple domains with different task periods.
 - Automatic calculation of process data mapping, FMMU and sync manager configuration within each domain.
- Communication through several finite state machines.

- Automatic bus scanning after topology changes.
- Bus monitoring during operation.
- Automatic reconfiguration of slaves (for example after power failure) during operation.
- Distributed Clocks support (see [section 3.5](#)).
 - Configuration of the slave’s DC parameters through the application interface.
 - Synchronization (offset and drift compensation) of the distributed slave clocks to the reference clock.
 - Optional synchronization of the reference clock to the master clock or the other way round.
- CANopen over EtherCAT (CoE)
 - SDO upload, download and information service.
 - Slave configuration via SDOs.
 - SDO access from userspace and from the application.
- Ethernet over EtherCAT (EoE)
 - Transparent use of EoE slaves via virtual network interfaces.
 - Natively supports either a switched or a routed EoE network architecture.
- Vendor-specific over EtherCAT (VoE)
 - Communication with vendor-specific mailbox protocols via the API.
- File Access over EtherCAT (FoE)
 - Loading and storing files via the command-line tool.
 - Updating a slave’s firmware can be done easily.
- Servo Profile over EtherCAT (SoE)
 - Implemented according to IEC 61800-7 [\[16\]](#).
 - Storing IDN configurations, that are written to the slave during startup.
 - Accessing IDNs via the command-line tool.
 - Accessing IDNs at runtime via the user-space library.
- Userspace command-line-tool “ethercat” (see [section 7.1](#))
 - Detailed information about master, slaves, domains and bus configuration.
 - Setting the master’s debug level.
 - Reading/Writing alias addresses.
 - Listing slave configurations.
 - Viewing process data.

- SDO download/upload; listing SDO dictionaries.
- Loading and storing files via FoE.
- SoE IDN access.
- Access to slave registers.
- Slave SII (EEPROM) access.
- Controlling application-layer states.
- Generation of slave description XML and C-code from existing slaves.
- Seamless system integration though LSB compliance.
 - Master and network device configuration via sysconfig files.
 - Init script for master control.
 - Service file for systemd.
- Virtual read-only network interface for monitoring and debugging purposes.

1.2 License

The master code is released under the terms and conditions of the GNU General Public License (GPL [4]), version 2. Other developers, that want to use EtherCAT with Linux systems, are invited to use the master code or even participate on development.

To allow static linking of userspace application against the master's application interface (see [chapter 3](#)), the userspace library (see [section 7.2](#)) is licensed under the terms and conditions of the GNU Lesser General Public License (LGPL [5]), version 2.1.

2 Architecture

The EtherCAT master is integrated into the Linux kernel. This was an early design decision, which has been made for several reasons:

- Kernel code has significantly better realtime characteristics, i. e. less latency than userspace code. It was foreseeable, that a fieldbus master has a lot of cyclic work to do. Cyclic work is usually triggered by timer interrupts inside the kernel. The execution delay of a function that processes timer interrupts is less, when it resides in kernelspace, because there is no need of time-consuming context switches to a userspace process.
- It was also foreseeable, that the master code has to directly communicate with the Ethernet hardware. This has to be done in the kernel anyway (through network device drivers), which is one more reason for the master code being in kernelspace.

Figure 2.1 gives a general overview of the master architecture.

The components of the master environment are described below:

Master Module Kernel module containing one or more EtherCAT master instances (see section 2.1), the “Device Interface” (see section 4.6) and the “Application Interface” (see chapter 3).

Device Modules EtherCAT-capable Ethernet device driver modules, that offer their devices to the EtherCAT master via the device interface (see section 4.6). These modified network drivers can handle network devices used for EtherCAT operation and “normal” Ethernet devices in parallel. A master can accept a certain device and then is able to send and receive EtherCAT frames. Ethernet devices declined by the master module are connected to the kernel’s network stack as usual.

Application A program that uses the EtherCAT master (usually for cyclic exchange of process data with EtherCAT slaves). These programs are not part of the EtherCAT master code¹, but have to be generated or written by the user. An application can request a master through the application interface (see chapter 3). If this succeeds, it has the control over the master: It can provide a bus configuration and exchange process data. Applications can be kernel modules (that use the kernel application interface directly) or userspace programs, that use the application interface via the EtherCAT library (see section 7.2), or the RTDM library (see section 7.3).

¹Although there are some examples provided in the *examples/* directory.

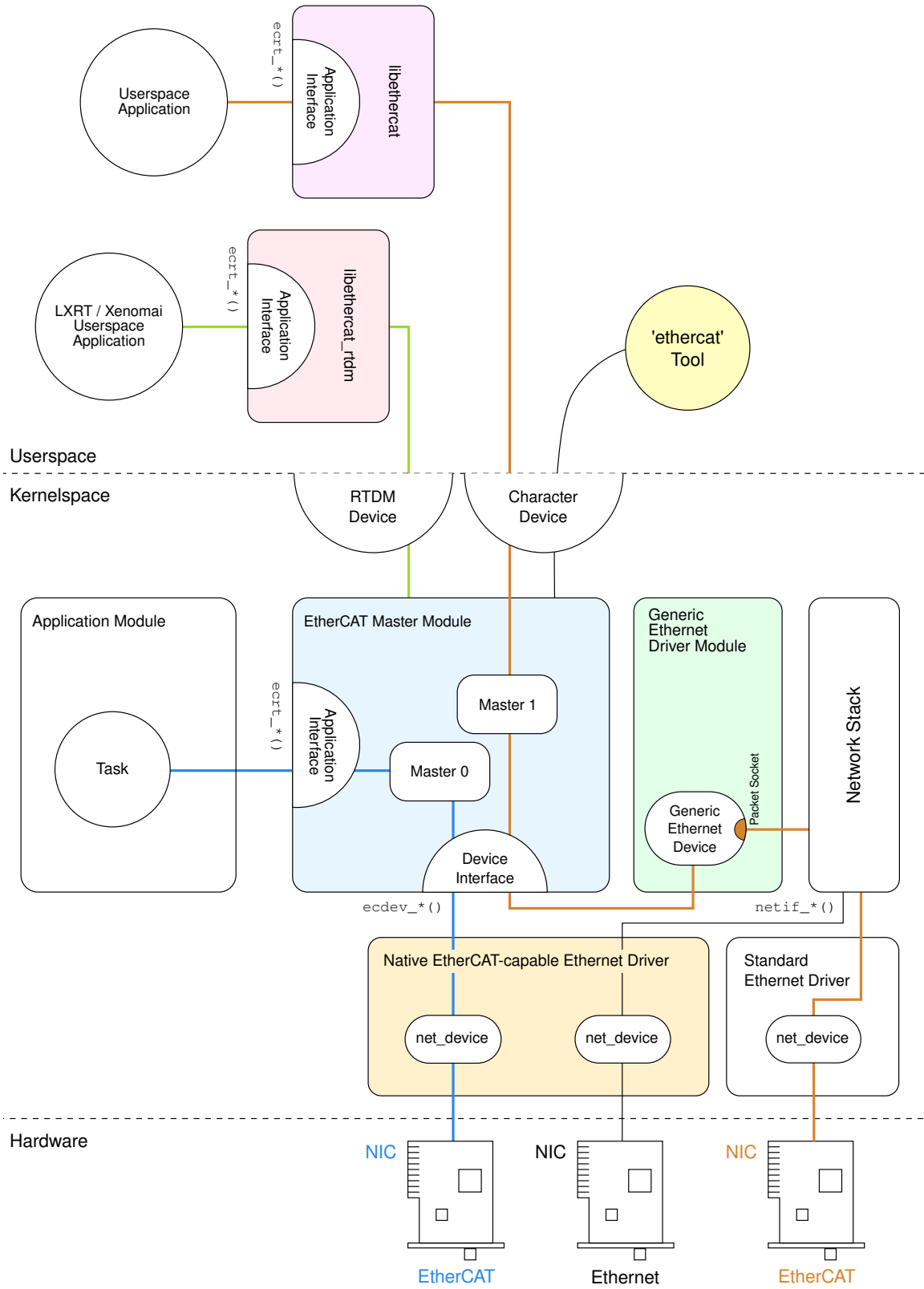

Figure 2.1: Master Architecture

2.1 Master Module

The EtherCAT master kernel module *ec_master* can contain multiple master instances. Each master waits for certain Ethernet device(s) identified by its MAC address(es). These addresses have to be specified on module loading via the *main_devices* (and optional: *backup_devices*) module parameter. The number of master instances to initialize is taken from the number of MAC addresses given.

The below command loads the master module with a single master instance that waits for one Ethernet device with the MAC address 00:0E:0C:DA:A2:20. The master will be accessible via index 0.

```
# modprobe ec_master main_devices=00:0E:0C:DA:A2:20
```

MAC addresses for multiple masters have to be separated by commas:

```
# modprobe ec_master main_devices=00:0E:0C:DA:A2:20,00:e0:81:71:d5:1c
```

The two masters can be addressed by their indices 0 and 1 respectively (see [Figure 2.2](#)). The master index is needed for the `ecrt_master_request()` function of the application interface (see [chapter 3](#)) and the `--master` option of the *ethercat* command-line tool (see [section 7.1](#)), which defaults to 0.

Debug Level The master module also has a parameter *debug_level* to set the initial debug level for all masters (see also [subsection 7.1.7](#)).

Init Script In most cases it is not necessary to load the master module and the Ethernet driver modules manually. There is an init script available, so the master can be started as a service (see [section 7.4](#)). For systems that are managed by systemd [7], there is also a service file available.

Syslog The master module outputs information about its state and events to the kernel ring buffer. These also end up in the system logs. The above module loading command should result in the messages below:

```
# dmesg | tail -2
EtherCAT: Master driver 1.6.0
EtherCAT: 2 masters waiting for devices.

# tail -2 /var/log/messages
Jul  4 10:22:45 ethercat kernel: EtherCAT: Master driver 1.6.0
Jul  4 10:22:45 ethercat kernel: EtherCAT: 2 masters waiting
                                for devices.
```

Master output is prefixed with EtherCAT which makes searching the logs easier.

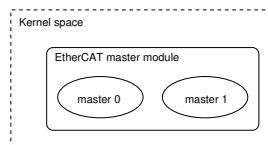

Figure 2.2: Multiple masters in one module

2.2 Master Phases

Every EtherCAT master provided by the master module (see [section 2.1](#)) runs through several phases (see [Figure 2.3](#)):

Orphaned phase This mode takes effect, when the master still waits for its Ethernet device(s) to connect. No bus communication is possible until then.

Idle phase takes effect when the master has accepted all required Ethernet devices, but is not requested by any application yet. The master runs its state machine (see [section 5.3](#)), that automatically scans the bus for slaves and executes pending operations from the userspace interface (for example SDO access). The command-line tool can be used to access the bus, but there is no process data exchange because of the missing bus configuration.

Operation phase The master is requested by an application that can provide a bus configuration and exchange process data.

2.3 Process Data

This section shall introduce a few terms and ideas how the master handles process data.

Process Data Image Slaves offer their inputs and outputs by presenting the master so-called “Process Data Objects” (PDOs). The available PDOs can be either determined by reading out the slave’s TxPDO and RxPDO SII categories from the E²PROM (in case of fixed PDOs) or by reading out the appropriate CoE objects (see [section 6.2](#)), if available. The application can register the PDOs’ entries for exchange during cyclic operation. The sum of all registered PDO entries defines the “process data image”, which is exchanged via datagrams with “logical” memory access (like LWR, LRD or LRW) introduced in [2, sec. 5.4].

Process Data Domains The process data image can be easily managed by creating so-called “domains”, which allow grouped PDO exchange. They also take care of managing the datagram structures needed to exchange the PDOs. Domains are mandatory for process data exchange, so there has to be at least one. They were introduced for the following reasons:

- The maximum size of a datagram is limited due to the limited size of an Ethernet frame: The maximum data size is the Ethernet data field size minus the EtherCAT frame header, EtherCAT datagram header and EtherCAT datagram footer: $1500 - 2 - 12 - 2 = 1484$ octets. If the size of the process data image exceeds this limit, multiple frames have to be sent, and the image has to be partitioned for the use of multiple datagrams. A domain manages this automatically.

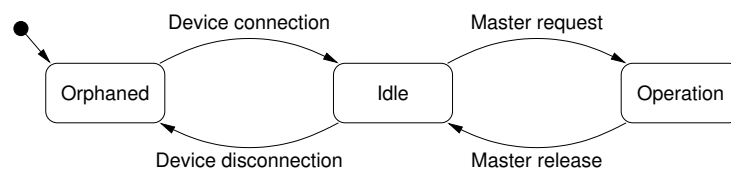

Figure 2.3: Master phases and transitions

- Not every PDO has to be exchanged with the same frequency: The values of PDOs can vary slowly over time (for example temperature values), so exchanging them with a high frequency would just waste bus bandwidth. For this reason, multiple domains can be created, to group different PDOs and so allow separate exchange.

There is no upper limit for the number of domains, but each domain occupies one FMMU in each slave involved, so the maximum number of domains is de facto limited by the slaves.

FMMU Configuration An application can register PDO entries for exchange. Every PDO entry and its parent PDO is part of a memory area in the slave's physical memory, that is protected by a sync manager [2, sec. 6.7] for synchronized access. In order to make a sync manager react on a datagram accessing its memory, it is necessary to access the last byte covered by the sync manager. Otherwise the sync manager will not react on the datagram and no data will be exchanged. That is why the whole synchronized memory area has to be included into the process data image: For example, if a certain PDO entry of a slave is registered for exchange with a certain domain, one FMMU will be configured to map the complete sync-manager-protected memory, the PDO entry resides in. If a second PDO entry of the same slave is registered for process data exchange within the same domain, and it resides in the same sync-manager-protected memory as the first one, the FMMU configuration is not altered, because the desired memory is already part of the domain's process data image. If the second PDO entry would belong to another sync-manager-protected area, this complete area would also be included into the domains process data image. [Figure 2.4](#) gives an overview, how FMMUs are configured to map physical memory to logical process data images.

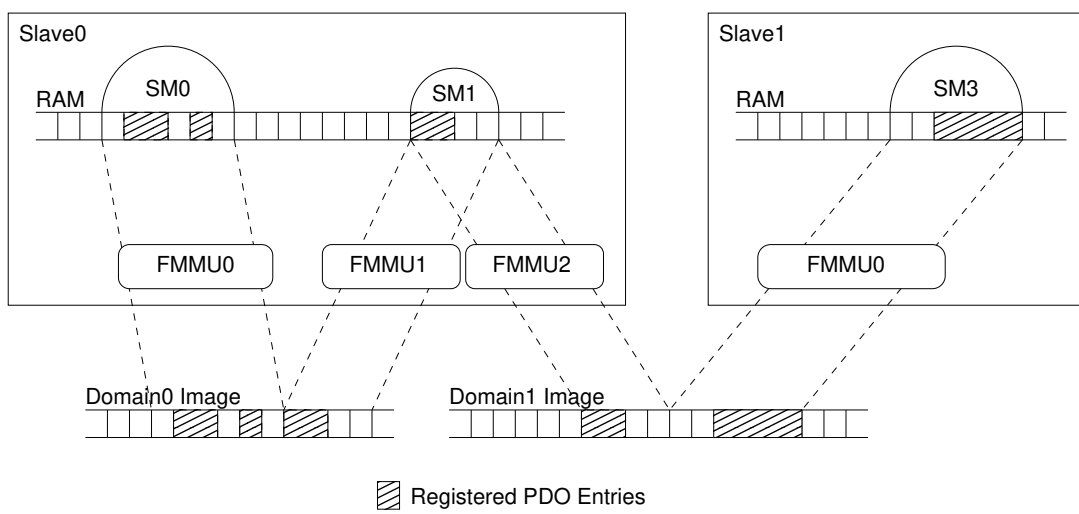

Figure 2.4: FMMU Configuration

3 Application Interface

The application interface provides functions and data structures for applications to access an EtherCAT master. The complete documentation of the interface is included as Doxygen [13] comments in the header file *include/ecrt.h* (see [section 3.6](#)). It can either be read directly from the file comments, or as a more comfortable HTML documentation. The HTML generation is described in [section 9.3](#).

The following sections cover a general description of the application interface.

Every application should use the master in two steps:

Configuration The master is requested and the configuration is applied. For example, domains are created, slaves are configured and PDO entries are registered (see [section 3.1](#)).

Operation Cyclic code is run and process data are exchanged (see [section 3.2](#)).

Example Applications There are a few example applications in the *examples/* sub-directory of the master code. They are documented in the source code.

3.1 Master Configuration

The bus configuration is supplied via the application interface. [Figure 3.1](#) gives an overview of the objects, that can be configured by the application.

3.1.1 Slave Configuration

The application has to tell the master about the expected bus topology. This can be done by creating “slave configurations”. A slave configuration can be seen as an expected slave. When a slave configuration is created, the application provides the bus position (see below), vendor id and product code.

When the bus configuration is applied, the master checks, if there is a slave with the given vendor id and product code at the given position. If this is the case, the slave configuration is “attached” to the real slave on the bus and the slave is configured according to the settings provided by the application. The state of a slave configuration can either be queried via the application interface or via the command-line tool (see [subsection 7.1.3](#)).

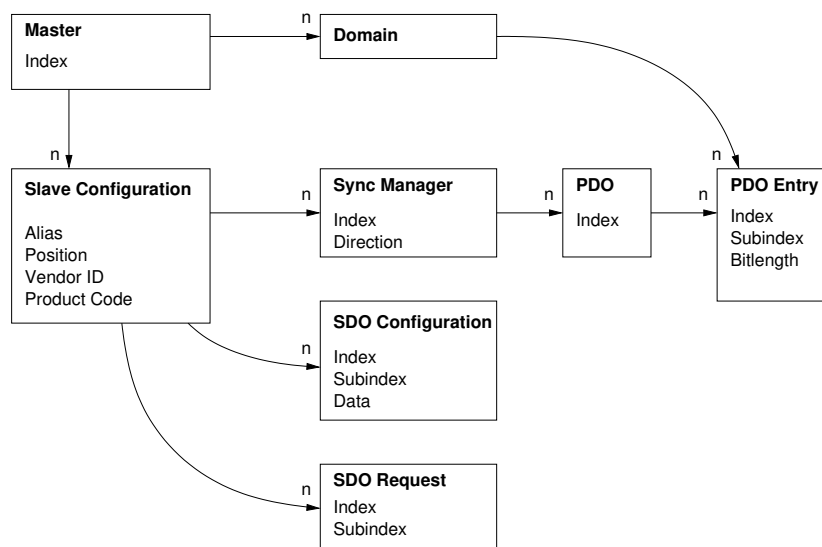

Figure 3.1: Master Configuration

Slave Position The slave position has to be specified as a tuple of “alias” and “position”. This allows addressing slaves either via an absolute bus position, or a stored identifier called “alias”, or a mixture of both. The alias is a 16-bit value stored in the slave’s E²PROM. It can be modified via the command-line tool (see [subsection 7.1.2](#)). [Table 3.1](#) shows, how the values are interpreted.

Table 3.1: Specifying a Slave Position

Alias	Position	Interpretation
0	0 – 65535	Position addressing. The position parameter is interpreted as the absolute ring position in the bus.
1 – 65535	0 – 65535	Alias addressing. The position parameter is interpreted as relative position after the first slave with the given alias address.

[Figure 3.2](#) shows an example of how slave configurations are attached. Some of the configurations were attached, while others remain detached. The below lists gives the reasons beginning with the top slave configuration.

1. A zero alias means to use simple position addressing. Slave 1 exists and vendor id and product code match the expected values.
2. Although the slave with position 0 is found, the product code does not match, so the configuration is not attached.
3. The alias is non-zero, so alias addressing is used. Slave 2 is the first slave with alias 0x2000. Because the position value is zero, the same slave is used.
4. There is no slave with the given alias, so the configuration can not be attached.
5. Slave 2 is again the first slave with the alias 0x2000, but position is now 1, so slave 3 is attached.

If the master sources are configured with `--enable-wildcards`, then `0xffffffff` matches every vendor ID and/or product code.

3.2 Cyclic Operation

To enter cyclic operation mode, the master has to be “activated” to calculate the process data image and apply the bus configuration for the first time. After activation, the application is in charge to send and receive frames. The configuration can not be changed after activation.

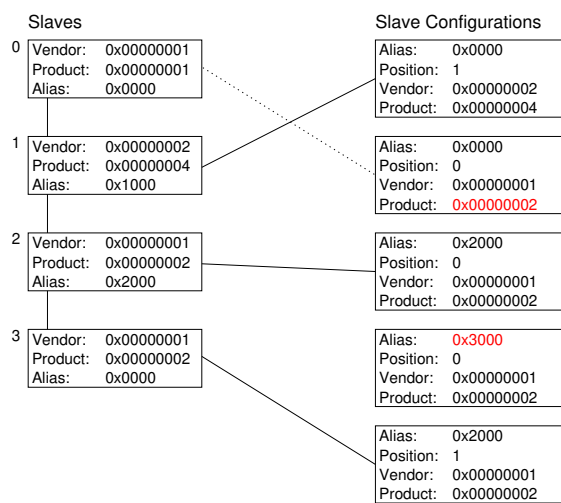

Figure 3.2: Slave Configuration Attachment

3.3 VoE Handlers

During the configuration phase, the application can create handlers for the VoE mailbox protocol described in [section 6.3](#). One VoE handler always belongs to a certain slave configuration, so the creation function is a method of the slave configuration.

A VoE handler manages the VoE data and the datagram used to transmit and receive VoE messages. It contains the state machine necessary to transfer VoE messages.

The VoE state machine can only process one operation at a time. As a result, either a read or write operation may be issued at a time¹. After the operation is initiated, the handler must be executed cyclically until it is finished. After that, the results of the operation can be retrieved.

A VoE handler has an own datagram structure, that is marked for exchange after each execution step. So the application can decide, how many handlers to execute before sending the corresponding EtherCAT frame(s).

For more information about the use of VoE handlers see the documentation of the application interface functions and the example applications provided in the *examples/* directory.

3.4 Concurrent Master Access

In some cases, one master is used by several instances, for example when an application does cyclic process data exchange, and there are EoE-capable slaves that require to exchange Ethernet data with the kernel (see [section 6.1](#)). For this reason, the master is a shared resource, and access to it has to be sequentialized. This is usually done by locking with semaphores, or other methods to protect critical sections.

The master itself can not provide locking mechanisms, because it has no chance to know the appropriate kind of lock. For example if the application is in kernelspace and uses RTAI functionality, ordinary kernel semaphores would not be sufficient. For that, an important design decision was made: The application that reserved a master must have the total control, therefore it has to take responsibility for providing the appropriate locking mechanisms. If another instance wants to access the master, it has to request the bus access via callbacks, that have to be provided by the application. Moreover the application can deny access to the master if it considers it to be awkward at the moment.

[Figure 3.3](#) exemplarily shows, how two processes share one master: The application's cyclic task uses the master for process data exchange, while the master-internal EoE process uses it to communicate with EoE-capable slaves. Both have to access the bus from time to time, but the EoE process does this by "asking" the application to do the bus access for it. In this way, the application can use the appropriate locking

¹If simultaneous sending and receiving is desired, two VoE handlers can be created for the slave configuration.

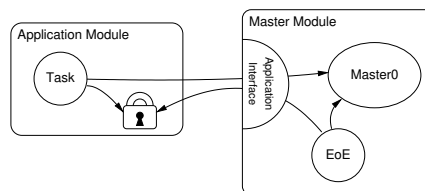

Figure 3.3: Concurrent Master Access

mechanism to avoid accessing the bus at the same time. See the application interface documentation ([chapter 3](#)) for how to use these callbacks.

3.5 Distributed Clocks

From version 1.5, the master supports EtherCAT’s “Distributed Clocks” feature. It is possible to synchronize the slave clocks on the bus to the “reference clock” (which is the local clock of the first slave with DC support) and to synchronize the reference clock to the “master clock” (which is the local clock of the master). All other clocks on the bus (after the reference clock) are considered as “slave clocks” (see [Figure 3.4](#)).

Local Clocks Any EtherCAT slave that supports DC has a local clock register with nanosecond resolution. If the slave is powered, the clock starts from zero, meaning that when slaves are powered on at different times, their clocks will have different values. These “offsets” have to be compensated by the distributed clocks mechanism. On the other hand, the clocks do not run exactly with the same speed, since the used quartz units have a natural frequency deviation. This deviation is usually very small, but over longer periods, the error would accumulate and the difference between local clocks would grow. This clock “drift” has also to be compensated by the DC mechanism.

Application Time The common time base for the bus has to be provided by the application. This application time t_{app} is used

1. to configure the slaves’ clock offsets (see below),
2. to program the slave’s start times for sync pulse generation (see below).
3. to synchronize the reference clock to the master clock (optional).

Offset Compensation For the offset compensation, each slave provides a “System Time Offset” register t_{off} , that is added to the internal clock value t_{int} to get the “System Time” t_{sys} :

$$\begin{aligned} t_{\text{sys}} &= t_{\text{int}} + t_{\text{off}} \\ \Rightarrow t_{\text{int}} &= t_{\text{sys}} - t_{\text{off}} \end{aligned} \tag{3.1}$$

The master reads the values of both registers to calculate a new system time offset in a way, that the resulting system time shall match the master’s application time t_{app} :

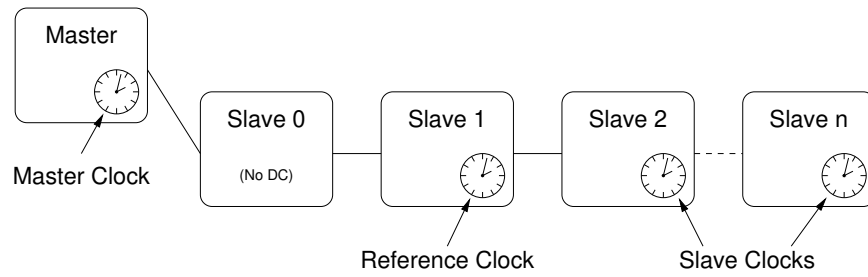

Figure 3.4: Distributed Clocks

$$\begin{aligned}
t_{\text{sys}} &\stackrel{!}{=} t_{\text{app}} & (3.2) \\
\Rightarrow t_{\text{int}} + t_{\text{off}} &\stackrel{!}{=} t_{\text{app}} \\
\Rightarrow t_{\text{off}} &= t_{\text{app}} - t_{\text{int}} \\
\Rightarrow t_{\text{off}} &= t_{\text{app}} - (t_{\text{sys}} - t_{\text{off}}) \\
\Rightarrow t_{\text{off}} &= t_{\text{app}} - t_{\text{sys}} + t_{\text{off}} & (3.3)
\end{aligned}$$

The small time offset error resulting from the different times of reading and writing the registers will be compensated by the drift compensation.

Drift Compensation The drift compensation is possible due to a special mechanism in each DC-capable slave: A write operation to the “System time” register will cause the internal time control loop to compare the written time (minus the programmed transmission delay, see below) to the current system time. The calculated time error will be used as an input to the time controller, that will tune the local clock speed to be a little faster or slower², according to the sign of the error.

Transmission Delays The Ethernet frame needs a small amount of time to get from slave to slave. The resulting transmission delay times accumulate on the bus and can reach microsecond magnitude and thus have to be considered during the drift compensation. EtherCAT slaves supporting DC provide a mechanism to measure the transmission delays: For each of the four slave ports there is a receive time register. A write operation to the receive time register of port 0 starts the measuring and the current system time is latched and stored in a receive time register once the frame is received on the corresponding port. The master can read out the relative receive times, then calculate time delays between the slaves (using its knowledge of the bus topology), and finally calculate the time delays from the reference clock to each slave. These values are programmed into the slaves’ transmission delay registers. In this way, the drift compensation can reach nanosecond synchrony.

Checking Synchrony DC-capable slaves provide the 32-bit “System time difference” register at address 0x092c, where the system time difference of the last drift compensation is stored in nanosecond resolution and in sign-and-magnitude coding³. To check for bus synchrony, the system time difference registers can also be cyclically read via the command-line-tool (see [subsection 7.1.16](#)):

```
$ watch -n0 "ethercat reg_read -p4 -tsm32 0x92c"
```

²The local slave clock will be incremented either with 9 ns, 10 ns or 11 ns every 10 ns.

³This allows broadcast-reading all system time difference registers on the bus to get an upper approximation

Sync Signals Synchronous clocks are only the prerequisite for synchronous events on the bus. Each slave with DC support provides two “sync signals”, that can be programmed to create events, that will for example cause the slave application to latch its inputs on a certain time. A sync event can either be generated once or cyclically, depending on what makes sense for the slave application. Programming the sync signals is a matter of setting the so-called “AssignActivate” word and the sync signals’ cycle- and shift times. The AssignActivate word is slave-specific and has to be taken from the XML slave description (`Device` → `Dc`), where also typical sync signal configurations “OpModes” can be found.

3.6 Application Interface Header

The application interface of the EtherCAT master is defined in the header file *include/ecrt.h* (acronym for “EtherCAT Real-Time”) which is listed in this section. The calling conventions of all methods are documented in the comments of this header. There is also a Doxygen-generated online version at <https://docs.etherlab.org>.

Listing 3.1: Application Interface Header ecrt.h

```
1 /*****
2 *
3 * Copyright (C) 2006-2024 Florian Pose, Ingenieurgesellschaft IgH
4 *
5 * This file is part of the IgH EtherCAT master userspace library.
6 *
7 * The IgH EtherCAT master userspace library is free software; you can
8 * redistribute it and/or modify it under the terms of the GNU Lesser General
9 * Public License as published by the Free Software Foundation; version 2.1
10 * of the License.
11 *
12 * The IgH EtherCAT master userspace library is distributed in the hope that
13 * it will be useful, but WITHOUT ANY WARRANTY; without even the implied
14 * warranty of MERCHANTABILITY or FITNESS FOR A PARTICULAR PURPOSE. See the
15 * GNU Lesser General Public License for more details.
16 *
17 * You should have received a copy of the GNU Lesser General Public License
18 * along with the IgH EtherCAT master userspace library. If not, see
19 * <http://www.gnu.org/licenses/>.
20 *
21 *****/
22
23 /** \file
24 *
25 * EtherCAT master application interface.
26 *
27 * \defgroup ApplicationInterface EtherCAT Application Interface
28 *
29 * EtherCAT interface for realtime applications. This interface is designed
30 * for realtime modules that want to use EtherCAT. There are functions to
31 * request a master, to map process data, to communicate with slaves via CoE
32 * and to configure and activate the bus.
33 *
34 *
35 * Changes in version 1.6.0:
36 *
37 * - Added the ecrt_master_scan_progress() method, the
```



```
38 *   ec_master_scan_progress_t structure and the EC_HAVE_SCAN_PROGRESS
39 *   definition to check for its existence.
40 * - Added the EoE configuration methods ecrt_slave_config_eoe_mac_address(),
41 *   ecrt_slave_config_eoe_ip_address(), ecrt_slave_config_eoe_subnet_mask(),
42 *   ecrt_slave_config_eoe_default_gateway(),
43 *   ecrt_slave_config_eoe_dns_address(),
44 *   ecrt_slave_config_eoe_hostname() and the EC_HAVE_SET_IP
45 *   definition to check for its existence.
46 * - Added ecrt_slave_config_state_timeout() to set the application-layer
47 *   state change timeout and EC_HAVE_STATE_TIMEOUT to check for its
48 *   existence.
49 *
50 * Changes since version 1.5.2:
51 *
52 * - Added the ecrt_slave_config_flag() method and the EC_HAVE_FLAGS
53 *   definition to check for its existence.
54 * - Added SoE IDN requests, including the datatype ec_soe_request_t and the
55 *   methods ecrt_slave_config_create_soe_request(),
56 *   ecrt_soe_request_object(), ecrt_soe_request_timeout(),
57 *   ecrt_soe_request_data(), ecrt_soe_request_data_size(),
58 *   ecrt_soe_request_state(), ecrt_soe_request_write() and
59 *   ecrt_soe_request_read(). Use the EC_HAVE_SOE_REQUESTS to check, if the
60 *   functionality is available.
61 *
62 * Changes in version 1.5.2:
63 *
64 * - Added redundancy_active flag to ec_domain_state_t.
65 * - Added ecrt_master_link_state() method and ec_master_link_state_t to query
66 *   the state of a redundant link.
67 * - Added the EC_HAVE_REDUNDANCY define, to check, if the interface contains
68 *   redundancy features.
69 * - Added ecrt_sdo_request_index() to change SDO index and subindex after
70 *   request creation.
71 * - Added interface for retrieving CoE emergency messages, i. e.
72 *   ecrt_slave_config_emerg_size(), ecrt_slave_config_emerg_pop(),
73 *   ecrt_slave_config_emerg_clear(), ecrt_slave_config_emerg_overruns() and
74 *   the defines EC_HAVE_EMERGENCY and EC_COE_EMERGENCY_MSG_SIZE.
75 * - Added interface for direct EtherCAT register access: Added data type
76 *   ec_reg_request_t and methods ecrt_slave_config_create_reg_request(),
77 *   ecrt_reg_request_data(), ecrt_reg_request_state(),
78 *   ecrt_reg_request_write(), ecrt_reg_request_read() and the feature flag
79 *   EC_HAVE_REG_ACCESS.
80 * - Added method to select the reference clock,
81 *   ecrt_master_select_reference_clock() and the feature flag
82 *   EC_HAVE_SELECT_REF_CLOCK to check, if the method is available.
83 * - Added method to get the reference clock time,
84 *   ecrt_master_reference_clock_time() and the feature flag
85 *   EC_HAVE_REF_CLOCK_TIME to have the possibility to synchronize the master
86 *   clock to the reference clock.
87 * - Changed the data types of the shift times in ecrt_slave_config_dc() to
88 *   int32_t to correctly display negative shift times.
89 * - Added ecrt_slave_config_reg_pdo_entry_pos() and the feature flag
90 *   EC_HAVE_REG_BY_POS for registering PDO entries with non-unique indices
91 *   via their positions in the mapping.
92 *
93 * Changes in version 1.5:
94 *
95 * - Added the distributed clocks feature and the respective method
96 *   ecrt_slave_config_dc() to configure a slave for cyclic operation, and
97 *   ecrt_master_application_time(), ecrt_master_sync_reference_clock() and
98 *   ecrt_master_sync_slave_clocks() for offset and drift compensation. The
99 *   EC_TIMEVAL2NANO() macro can be used for epoch time conversion, while the
100 *   ecrt_master_sync_monitor_queue() and ecrt_master_sync_monitor_process()
101 *   methods can be used to monitor the synchrony.
102 * - Improved the callback mechanism. ecrt_master_callbacks() now takes two
103 *   callback functions for sending and receiving datagrams.
```

```

104 *   ecrt_master_send_ext() is used to execute the sending of non-application
105 *   datagrams.
106 * - Added watchdog configuration (method ecrt_slave_config_watchdog(),
107 *   #ec_watchdog_mode_t, \a watchdog_mode parameter in ec_sync_info_t and
108 *   ecrt_slave_config_sync_manager()).
109 * - Added ecrt_slave_config_complete_sdo() method to download an SDO during
110 *   configuration via CompleteAccess.
111 * - Added ecrt_master_deactivate() to remove the master configuration.
112 * - Added ecrt_open_master() and ecrt_master_reserve() separation for
113 *   userspace.
114 * - Added master information interface (methods ecrt_master(),
115 *   ecrt_master_get_slave(), ecrt_master_get_sync_manager(),
116 *   ecrt_master_get_pdo() and ecrt_master_get_pdo_entry()) to get information
117 *   about the currently connected slaves and the PDO entries provided.
118 * - Added ecrt_master_sdo_download(), ecrt_master_sdo_download_complete() and
119 *   ecrt_master_sdo_upload() methods to let an application transfer SDOs
120 *   before activating the master.
121 * - Changed the meaning of the negative return values of
122 *   ecrt_slave_config_reg_pdo_entry() and ecrt_slave_config_sdo*().
123 * - Implemented the Vendor-specific over EtherCAT mailbox protocol. See
124 *   ecrt_slave_config_create_voe_handler().
125 * - Renamed ec_sdo_request_state_t to #ec_request_state_t, because it is also
126 *   used by VoE handlers.
127 * - Removed 'const' from argument of ecrt_sdo_request_state(), because the
128 *   userspace library has to modify object internals.
129 * - Added 64-bit data access macros.
130 * - Added ecrt_slave_config_idn() method for storing SoE IDN configurations,
131 *   and ecrt_master_read_idn() and ecrt_master_write_idn() to read/write IDNs
132 *   ad-hoc via the user-space library.
133 * - Added ecrt_master_reset() to initiate retrying to configure slaves.
134 *
135 * @{
136 */
137
138 /*****
139
140 #ifndef __ECRT_H__
141 #define __ECRT_H__
142
143 #ifdef __KERNEL__
144 #include <asm/byteorder.h>
145 #include <linux/types.h>
146 #include <linux/time.h>
147 #include <linux/in.h> // struct in_addr
148 #else
149 #include <stdlib.h> // for size_t
150 #include <stdint.h>
151 #include <sys/time.h> // for struct timeval
152 #include <netinet/in.h> // struct in_addr
153 #endif
154
155 /*****
156 * Global definitions
157 *****/
158
159 /** EtherCAT realtime interface major version number.
160 */
161 #define ECRT_VER_MAJOR 1
162
163 /** EtherCAT realtime interface minor version number.
164 */
165 #define ECRT_VER_MINOR 6
166
167 /** EtherCAT realtime interface version word generator.
168 */
169 #define ECRT_VERSION(a, b) (((a) << 8) + (b))

```

```

170
171 /** EtherCAT realtime interface version word.
172 */
173 #define ECRT_VERSION_MAGIC ECRT_VERSION(ECRT_VER_MAJOR, ECRT_VER_MINOR)
174
175 /*****
176 * Feature flags
177 *****/
178
179 /** Defined, if the redundancy features are available.
180 *
181 * I. e. if the \a redundancy_active flag in ec_domain_state_t and the
182 * ecrt_master_link_state() method are available.
183 */
184 #define EC_HAVE_REDUNDANCY
185
186 /** Defined, if the CoE emergency ring feature is available.
187 *
188 * I. e. if the ecrt_slave_config_emerg_*() methods are available.
189 */
190 #define EC_HAVE_EMERGENCY
191
192 /** Defined, if the register access interface is available.
193 *
194 * I. e. if the methods ecrt_slave_config_create_reg_request(),
195 * ecrt_reg_request_data(), ecrt_reg_request_state(), ecrt_reg_request_write()
196 * and ecrt_reg_request_read() are available.
197 */
198 #define EC_HAVE_REG_ACCESS
199
200 /** Defined if the method ecrt_master_select_reference_clock() is available.
201 */
202 #define EC_HAVE_SELECT_REF_CLOCK
203
204 /** Defined if the method ecrt_master_reference_clock_time() is available.
205 */
206 #define EC_HAVE_REF_CLOCK_TIME
207
208 /** Defined if the method ecrt_slave_config_reg_pdo_entry_pos() is available.
209 */
210 #define EC_HAVE_REG_BY_POS
211
212 /** Defined if the method ecrt_master_sync_reference_clock_to() is available.
213 */
214 #define EC_HAVE_SYNC_TO
215
216 /** Defined if the method ecrt_slave_config_flag() is available.
217 */
218 #define EC_HAVE_FLAGS
219
220 /** Defined if the methods ecrt_slave_config_create_soe_request(),
221 * ecrt_soe_request_object(), ecrt_soe_request_timeout(),
222 * ecrt_soe_request_data(), ecrt_soe_request_data_size(),
223 * ecrt_soe_request_state(), ecrt_soe_request_write() and
224 * ecrt_soe_request_read() and the datatype ec_soe_request_t are available.
225 */
226 #define EC_HAVE_SOE_REQUESTS
227
228 /** Defined, if the method ecrt_master_scan_progress() and the
229 * ec_master_scan_progress_t structure are available.
230 */
231 #define EC_HAVE_SCAN_PROGRESS
232
233 /** Defined, if the methods ecrt_slave_config_eoe_mac_address(),
234 * ecrt_slave_config_eoe_ip_address(), ecrt_slave_config_eoe_subnet_mask(),
235 * ecrt_slave_config_eoe_default_gateway(),

```

```

236 * ecrt_slave_config_eoe_dns_address(), ecrt_slave_config_eoe_hostname() are
237 * available.
238 */
239 #define EC_HAVE_SET_IP
240
241 /** Defined, if the method ecrt_slave_config_state_timeout() is available.
242 */
243 #define EC_HAVE_STATE_TIMEOUT
244
245 /*****
246
247 /** Symbol visibility control macro.
248 */
249 #ifndef EC_PUBLIC_API
250 # if defined(ethercat_EXPORTS) && !defined(__KERNEL__)
251 #  define EC_PUBLIC_API __attribute__((visibility ("default")))
252 # else
253 #  define EC_PUBLIC_API
254 # endif
255 #endif
256
257 /*****
258
259 /** End of list marker.
260 *
261 * This can be used with ecrt_slave_config_pdos().
262 */
263 #define EC_END ~0U
264
265 /** Maximum number of sync managers per slave.
266 */
267 #define EC_MAX_SYNC MANAGERS 16
268
269 /** Maximum string length.
270 *
271 * Used in ec_slave_info_t.
272 */
273 #define EC_MAX_STRING_LENGTH 64
274
275 /** Maximum number of slave ports. */
276 #define EC_MAX_PORTS 4
277
278 /** Timeval to nanoseconds conversion.
279 *
280 * This macro converts a Unix epoch time to EtherCAT DC time.
281 *
282 * \see void ecrt_master_application_time()
283 *
284 * \param TV struct timeval containing epoch time.
285 */
286 #define EC_TIMEVAL2NANO(TV) \
287     (((TV).tv_sec - 946684800ULL) * 1000000000ULL + (TV).tv_usec * 1000ULL)
288
289 /** Size of a CoE emergency message in byte.
290 *
291 * \see ecrt_slave_config_emerg_pop().
292 */
293 #define EC_COE_EMERGENCY_MSG_SIZE 8
294
295 /*****
296 * Data types
297 *****/
298
299 struct ec_master;
300 typedef struct ec_master ec_master_t; /**< \see ec_master */
301

```

```

302 struct ec_slave_config;
303 typedef struct ec_slave_config ec_slave_config_t; /**< \see ec_slave_config */
304
305 struct ec_domain;
306 typedef struct ec_domain ec_domain_t; /**< \see ec_domain */
307
308 struct ec_sdo_request;
309 typedef struct ec_sdo_request ec_sdo_request_t; /**< \see ec_sdo_request. */
310
311 struct ec_soe_request;
312 typedef struct ec_soe_request ec_soe_request_t; /**< \see ec_soe_request. */
313
314 struct ec_voe_handler;
315 typedef struct ec_voe_handler ec_voe_handler_t; /**< \see ec_voe_handler. */
316
317 struct ec_reg_request;
318 typedef struct ec_reg_request ec_reg_request_t; /**< \see ec_reg_request. */
319
320 /*****
321
322 /** Master state.
323  *
324  * This is used for the output parameter of ecrt_master_state().
325  *
326  * \see ecrt_master_state().
327  */
328 typedef struct {
329     unsigned int slaves_responding; /**< Sum of responding slaves on all
330                                     Ethernet devices. */
331     unsigned int al_states : 4; /**< Application-layer states of all slaves.
332                                     The states are coded in the lower 4 bits.
333                                     If a bit is set, it means that at least one
334                                     slave in the network is in the corresponding
335                                     state:
336                                     - Bit 0: \a INIT
337                                     - Bit 1: \a PREOP
338                                     - Bit 2: \a SAFEOP
339                                     - Bit 3: \a OP */
340     unsigned int link_up : 1; /**< \a true, if at least one Ethernet link is
341                                     up. */
342 } ec_master_state_t;
343
344 /*****
345
346 /** Redundant link state.
347  *
348  * This is used for the output parameter of ecrt_master_link_state().
349  *
350  * \see ecrt_master_link_state().
351  */
352 typedef struct {
353     unsigned int slaves_responding; /**< Sum of responding slaves on the given
354                                     link. */
355     unsigned int al_states : 4; /**< Application-layer states of the slaves on
356                                     the given link. The states are coded in the
357                                     lower 4 bits. If a bit is set, it means
358                                     that at least one slave in the network is in
359                                     the corresponding state:
360                                     - Bit 0: \a INIT
361                                     - Bit 1: \a PREOP
362                                     - Bit 2: \a SAFEOP
363                                     - Bit 3: \a OP */
364     unsigned int link_up : 1; /**< \a true, if the given Ethernet link is up.
365                                     */
366 } ec_master_link_state_t;
367

```

```
368 /*****  
369  
370 /** Slave configuration state.  
371  *  
372  * This is used as an output parameter of ecrt_slave_config_state().  
373  *  
374  * \see ecrt_slave_config_state().  
375  */  
376 typedef struct {  
377     unsigned int online : 1; /**< The slave is online. */  
378     unsigned int operational : 1; /**< The slave was brought into \a OP state  
379         using the specified configuration. */  
380     unsigned int al_state : 4; /**< The application-layer state of the slave.  
381         - 1: \a INIT  
382         - 2: \a PREOP  
383         - 4: \a SAFEOP  
384         - 8: \a OP  
385  
386         Note that each state is coded in a different  
387         bit! */  
388 } ec_slave_config_state_t;  
389  
390 /*****  
391  
392 /** Master information.  
393  *  
394  * This is used as an output parameter of ecrt_master().  
395  *  
396  * \see ecrt_master().  
397  */  
398 typedef struct {  
399     unsigned int slave_count; /**< Number of slaves in the network. */  
400     unsigned int link_up : 1; /**< \a true, if the network link is up. */  
401     uint8_t scan_busy; /**< \a true, while the master is scanning the network.  
402         */  
403     uint64_t app_time; /**< Application time. */  
404 } ec_master_info_t;  
405  
406 /*****  
407  
408 /** Master scan progress information.  
409  *  
410  * This is used as an output parameter of ecrt_master_scan_progress().  
411  *  
412  * \see ecrt_master_scan_progress().  
413  */  
414 typedef struct {  
415     unsigned int slave_count; /**< Number of slaves detected. */  
416     unsigned int scan_index; /**< Index of the slave that is currently  
417         scanned. If it is less than the \a  
418         slave_count, the network scan is in progress.  
419         */  
420 } ec_master_scan_progress_t;  
421  
422 /*****  
423  
424 /** EtherCAT slave port descriptor.  
425  */  
426 typedef enum {  
427     EC_PORT_NOT_IMPLEMENTED, /**< Port is not implemented. */  
428     EC_PORT_NOT_CONFIGURED, /**< Port is not configured. */  
429     EC_PORT_EBUS, /**< Port is an E-Bus. */  
430     EC_PORT_MII /**< Port is a MII. */  
431 } ec_slave_port_desc_t;  
432  
433 /*****
```

```

434
435 /** EtherCAT slave port information.
436 */
437 typedef struct {
438     uint8_t link_up; /**< Link detected. */
439     uint8_t loop_closed; /**< Loop closed. */
440     uint8_t signal_detected; /**< Detected signal on RX port. */
441 } ec_slave_port_link_t;
442
443 /*****
444
445 /** Slave information.
446 *
447 * This is used as an output parameter of ecrt_master_get_slave().
448 *
449 * \see ecrt_master_get_slave().
450 */
451 typedef struct {
452     uint16_t position; /**< Offset of the slave in the ring. */
453     uint32_t vendor_id; /**< Vendor-ID stored on the slave. */
454     uint32_t product_code; /**< Product-Code stored on the slave. */
455     uint32_t revision_number; /**< Revision-Number stored on the slave. */
456     uint32_t serial_number; /**< Serial-Number stored on the slave. */
457     uint16_t alias; /**< The slaves alias if not equal to 0. */
458     int16_t current_on_ebus; /**< Used current in mA. */
459     struct {
460         ec_slave_port_desc_t desc; /**< Physical port type. */
461         ec_slave_port_link_t link; /**< Port link state. */
462         uint32_t receive_time; /**< Receive time on DC transmission delay
463             measurement. */
464         uint16_t next_slave; /**< Ring position of next DC slave on that
465             port. */
466         uint32_t delay_to_next_dc; /**< Delay [ns] to next DC slave. */
467     } ports[EC_MAX_PORTS]; /**< Port information. */
468     uint8_t al_state; /**< Current state of the slave. */
469     uint8_t error_flag; /**< Error flag for that slave. */
470     uint8_t sync_count; /**< Number of sync managers. */
471     uint16_t sdo_count; /**< Number of SDOs. */
472     char name[EC_MAX_STRING_LENGTH]; /**< Name of the slave. */
473 } ec_slave_info_t;
474
475 /*****
476
477 /** Domain working counter interpretation.
478 *
479 * This is used in ec_domain_state_t.
480 */
481 typedef enum {
482     EC_WC_ZERO = 0, /**< No registered process data were exchanged. */
483     EC_WC_INCOMPLETE, /**< Some of the registered process data were
484         exchanged. */
485     EC_WC_COMPLETE /**< All registered process data were exchanged. */
486 } ec_wc_state_t;
487
488 /*****
489
490 /** Domain state.
491 *
492 * This is used for the output parameter of ecrt_domain_state().
493 */
494 typedef struct {
495     unsigned int working_counter; /**< Value of the last working counter. */
496     ec_wc_state_t wc_state; /**< Working counter interpretation. */
497     unsigned int redundancy_active; /**< Redundant link is in use. */
498 } ec_domain_state_t;
499

```

```
500 /*****  
501  
502 /** Direction type for PDO assignment functions.  
503 */  
504 typedef enum {  
505     EC_DIR_INVALID, /**< Invalid direction. Do not use this value. */  
506     EC_DIR_OUTPUT, /**< Values written by the master. */  
507     EC_DIR_INPUT, /**< Values read by the master. */  
508     EC_DIR_COUNT /**< Number of directions. For internal use only. */  
509 } ec_direction_t;  
510  
511 /*****  
512  
513 /** Watchdog mode for sync manager configuration.  
514 *  
515 * Used to specify, if a sync manager's watchdog is to be enabled.  
516 */  
517 typedef enum {  
518     EC_WD_DEFAULT, /**< Use the default setting of the sync manager. */  
519     EC_WD_ENABLE, /**< Enable the watchdog. */  
520     EC_WD_DISABLE, /**< Disable the watchdog. */  
521 } ec_watchdog_mode_t;  
522  
523 /*****  
524  
525 /** PDO entry configuration information.  
526 *  
527 * This is the data type of the \a entries field in ec_pdo_info_t.  
528 *  
529 * \see ecrt_slave_config_pdos().  
530 */  
531 typedef struct {  
532     uint16_t index; /**< PDO entry index. */  
533     uint8_t subindex; /**< PDO entry subindex. */  
534     uint8_t bit_length; /**< Size of the PDO entry in bit. */  
535 } ec_pdo_entry_info_t;  
536  
537 /*****  
538  
539 /** PDO configuration information.  
540 *  
541 * This is the data type of the \a pdos field in ec_sync_info_t.  
542 *  
543 * \see ecrt_slave_config_pdos().  
544 */  
545 typedef struct {  
546     uint16_t index; /**< PDO index. */  
547     unsigned int n_entries; /**< Number of PDO entries in \a entries to map.  
548                               Zero means, that the default mapping shall be  
549                               used (this can only be done if the slave is  
550                               present at configuration time). */  
551     ec_pdo_entry_info_t const *entries; /**< Array of PDO entries to map. Can  
552                                           either be \a NULL, or must contain  
553                                           at least \a n_entries values. */  
554 } ec_pdo_info_t;  
555  
556 /*****  
557  
558 /** Sync manager configuration information.  
559 *  
560 * This can be use to configure multiple sync managers including the PDO  
561 * assignment and PDO mapping. It is used as an input parameter type in  
562 * ecrt_slave_config_pdos().  
563 */  
564 typedef struct {  
565     uint8_t index; /**< Sync manager index. Must be less
```



```

566         than #EC_MAX_SYNC MANAGERS for a valid sync manager,
567         but can also be \a 0xff to mark the end of the list. */
568     ec_direction_t dir; /**< Sync manager direction. */
569     unsigned int n_pdos; /**< Number of PDOs in \a pdos. */
570     ec_pdo_info_t const *pdos; /**< Array with PDOs to assign. This must
571         contain at least \a n_pdos PDOs. */
572     ec_watchdog_mode_t watchdog_mode; /**< Watchdog mode. */
573 } ec_sync_info_t;
574
575 /*****
576
577 /** List record type for PDO entry mass-registration.
578  *
579  * This type is used for the array parameter of the
580  * ecrt_domain_reg_pdo_entry_list()
581  */
582 typedef struct {
583     uint16_t alias; /**< Slave alias address. */
584     uint16_t position; /**< Slave position. */
585     uint32_t vendor_id; /**< Slave vendor ID. */
586     uint32_t product_code; /**< Slave product code. */
587     uint16_t index; /**< PDO entry index. */
588     uint8_t subindex; /**< PDO entry subindex. */
589     unsigned int *offset; /**< Pointer to a variable to store the PDO entry's
590         (byte-)offset in the process data. */
591     unsigned int *bit_position; /**< Pointer to a variable to store a bit
592         position (0-7) within the \a offset. Can be
593         NULL, in which case an error is raised if
594         the PDO entry does not byte-align. */
595 } ec_pdo_entry_reg_t;
596
597 /*****
598
599 /** Request state.
600  *
601  * This is used as return type for ecrt_sdo_request_state() and
602  * ecrt_voe_handler_state().
603  */
604 typedef enum {
605     EC_REQUEST_UNUSED, /**< Not requested. */
606     EC_REQUEST_BUSY, /**< Request is being processed. */
607     EC_REQUEST_SUCCESS, /**< Request was processed successfully. */
608     EC_REQUEST_ERROR, /**< Request processing failed. */
609 } ec_request_state_t;
610
611 /*****
612
613 /** Application-layer state.
614  */
615 typedef enum {
616     EC_AL_STATE_INIT = 1, /**< Init. */
617     EC_AL_STATE_PREOP = 2, /**< Pre-operational. */
618     EC_AL_STATE_SAFEOP = 4, /**< Safe-operational. */
619     EC_AL_STATE_OP = 8, /**< Operational. */
620 } ec_al_state_t;
621
622 /*****
623  * Global functions
624  *****/
625
626 #ifdef __cplusplus
627 extern "C" {
628 #endif
629
630 /** Returns the version magic of the realtime interface.
631  */

```

```
632 * \apiusage{master_any,rt_safe}
633 *
634 * \return Value of ECRT_VERSION_MAGIC() at EtherCAT master compile time.
635 */
636 EC_PUBLIC_API unsigned int ecrt_version_magic(void);
637
638 /** Requests an EtherCAT master for realtime operation.
639 *
640 * Before an application can access an EtherCAT master, it has to reserve one
641 * for exclusive use.
642 *
643 * In userspace, this is a convenience function for ecrt_open_master() and
644 * ecrt_master_reserve().
645 *
646 * This function has to be the first function an application has to call to
647 * use EtherCAT. The function takes the index of the master as its argument.
648 * The first master has index 0, the n-th master has index n - 1. The number
649 * of masters has to be specified when loading the master module.
650 *
651 * \apiusage{master_idle,blocking}
652 *
653 * \return Pointer to the reserved master, otherwise \a NULL.
654 */
655 EC_PUBLIC_API ec_master_t *ecrt_request_master(
656     unsigned int master_index /**< Index of the master to request. */
657 );
658
659 #ifndef __KERNEL__
660
661 /** Opens an EtherCAT master for userspace access.
662 *
663 * This function has to be the first function an application has to call to
664 * use EtherCAT. The function takes the index of the master as its argument.
665 * The first master has index 0, the n-th master has index n - 1. The number
666 * of masters has to be specified when loading the master module.
667 *
668 * For convenience, the function ecrt_request_master() can be used.
669 *
670 * \apiusage{master_idle,blocking}
671 *
672 * \return Pointer to the opened master, otherwise \a NULL.
673 */
674 EC_PUBLIC_API ec_master_t *ecrt_open_master(
675     unsigned int master_index /**< Index of the master to request. */
676 );
677
678 #endif // #ifndef __KERNEL__
679
680 /** Releases a requested EtherCAT master.
681 *
682 * After use, a master it has to be released to make it available for other
683 * applications.
684 *
685 * This method frees all created data structures. It should not be called in
686 * realtime context.
687 *
688 * If the master was activated, ecrt_master_deactivate() is called internally.
689 *
690 * \apiusage{master_any,blocking}
691 */
692 EC_PUBLIC_API void ecrt_release_master(
693     ec_master_t *master /**< EtherCAT master */
694 );
695
696 /*****
697 * Master methods
```

```

698  *****/
699
700 #ifndef __KERNEL__
701
702 /** Reserves an EtherCAT master for realtime operation.
703  *
704  * Before an application can use PDO/domain registration functions or SDO
705  * request functions on the master, it has to reserve one for exclusive use.
706  *
707  * \apiusage{master_idle,blocking}
708  *
709  * \return 0 in case of success, else < 0
710  */
711 EC_PUBLIC_API int ecrt_master_reserve(
712     ec_master_t *master /**< EtherCAT master */
713     );
714
715 #endif // #ifndef __KERNEL__
716
717 #ifdef __KERNEL__
718
719 /** Sets the locking callbacks.
720  *
721  * For concurrent master access, i. e. if other instances than the application
722  * want to send and receive datagrams on the network, the application has to
723  * provide a callback mechanism. This method takes two function pointers as
724  * its parameters. Asynchronous master access (like EoE processing) is only
725  * possible if the callbacks have been set.
726  *
727  * The task of the send callback (\a send_cb) is to decide, if the network
728  * hardware is currently accessible and whether or not to call the
729  * ecrt_master_send_ext() method.
730  *
731  * The task of the receive callback (\a receive_cb) is to decide, if a call to
732  * ecrt_master_receive() is allowed and to execute it respectively.
733  *
734  * \apiusage{master_idle,blocking}
735  *
736  * \attention This method has to be called before ecrt_master_activate().
737  */
738 void ecrt_master_callbacks(
739     ec_master_t *master, /**< EtherCAT master */
740     void (*send_cb)(void *), /**< Datagram sending callback. */
741     void (*receive_cb)(void *), /**< Receive callback. */
742     void *cb_data /**< Arbitrary pointer passed to the callback functions.
743     */
744     );
745
746 #endif /* __KERNEL__ */
747
748 /** Creates a new process data domain.
749  *
750  * For process data exchange, at least one process data domain is needed.
751  * This method creates a new process data domain and returns a pointer to the
752  * new domain object. This object can be used for registering PDOs and
753  * exchanging them in cyclic operation.
754  *
755  * This method allocates memory and should be called in non-realtime context
756  * before ecrt_master_activate().
757  *
758  * \apiusage{master_idle,blocking}
759  *
760  * \return Pointer to the new domain on success, else NULL.
761  */
762 EC_PUBLIC_API ec_domain_t *ecrt_master_create_domain(
763     ec_master_t *master /**< EtherCAT master. */

```

```
764     );
765
766 /** Obtains a slave configuration.
767 *
768 * Creates a slave configuration object for the given \a alias and \a position
769 * tuple and returns it. If a configuration with the same \a alias and \a
770 * position already exists, it will be re-used. In the latter case, the given
771 * vendor ID and product code are compared to the stored ones. On mismatch, an
772 * error message is raised and the function returns \a NULL.
773 *
774 * Slaves are addressed with the \a alias and \a position parameters.
775 * - If \a alias is zero, \a position is interpreted as the desired slave's
776 *   ring position.
777 * - If \a alias is non-zero, it matches a slave with the given alias. In this
778 *   case, \a position is interpreted as ring offset, starting from the
779 *   aliased slave, so a position of zero means the aliased slave itself and a
780 *   positive value matches the n-th slave behind the aliased one.
781 *
782 * If the slave with the given address is found during the configuration,
783 * its vendor ID and product code are matched against the given value. On
784 * mismatch, the slave is not configured and an error message is raised.
785 *
786 * If different slave configurations are pointing to the same slave during
787 * configuration, a warning is raised and only the first configuration is
788 * applied.
789 *
790 * This method allocates memory and should be called in non-realtime context
791 * before ecrt_master_activate().
792 *
793 * \apiusage{master_idle,blocking}
794 *
795 * \retval >0 Pointer to the slave configuration structure.
796 * \retval NULL in the error case.
797 */
798 EC_PUBLIC_API ec_slave_config_t *ecrt_master_slave_config(
799     ec_master_t *master, /**< EtherCAT master */
800     uint16_t alias, /**< Slave alias. */
801     uint16_t position, /**< Slave position. */
802     uint32_t vendor_id, /**< Expected vendor ID. */
803     uint32_t product_code /**< Expected product code. */
804 );
805
806 /** Selects the reference clock for distributed clocks.
807 *
808 * If this method is not called for a certain master, or if the slave
809 * configuration pointer is NULL, then the first slave with DC functionality
810 * will provide the reference clock.
811 *
812 * \apiusage{master_idle,blocking}
813 *
814 * \return 0 on success, otherwise negative error code.
815 */
816 EC_PUBLIC_API int ecrt_master_select_reference_clock(
817     ec_master_t *master, /**< EtherCAT master. */
818     ec_slave_config_t *sc /**< Slave config of the slave to use as the
819     * reference slave (or NULL). */
820 );
821
822 /** Obtains master information.
823 *
824 * No memory is allocated on the heap in this function.
825 *
826 * \apiusage{master_any,rt_safe}
827 *
828 * \attention The pointer to this structure must point to a valid variable.
829 *
```

```

830 * \return 0 in case of success, else < 0
831 */
832 EC_PUBLIC_API int ecrt_master(
833     ec_master_t *master, /**< EtherCAT master */
834     ec_master_info_t *master_info /**< Structure that will output the
835                                     information */
836     );
837
838 /** Obtains network scan progress information.
839 *
840 * No memory is allocated on the heap in this function.
841 *
842 * \apiusage{master_any,rt_safe}
843 *
844 * \attention The pointer to this structure must point to a valid variable.
845 *
846 * \return 0 in case of success, else < 0
847 */
848 EC_PUBLIC_API int ecrt_master_scan_progress(
849     ec_master_t *master, /**< EtherCAT master */
850     ec_master_scan_progress_t *progress /**< Structure that will output
851                                     the progress information. */
852     );
853
854 /** Obtains slave information.
855 *
856 * Tries to find the slave with the given ring position. The obtained
857 * information is stored in a structure. No memory is allocated on the heap in
858 * this function.
859 *
860 * \apiusage{master_any,blocking}
861 *
862 * \attention The pointer to this structure must point to a valid variable.
863 *
864 * \return 0 in case of success, else < 0
865 */
866 EC_PUBLIC_API int ecrt_master_get_slave(
867     ec_master_t *master, /**< EtherCAT master */
868     uint16_t slave_position, /**< Slave position. */
869     ec_slave_info_t *slave_info /**< Structure that will output the
870                                     information */
871     );
872
873 #ifndef __KERNEL__
874
875 /** Returns the proposed configuration of a slave's sync manager.
876 *
877 * Fills a given ec_sync_info_t structure with the attributes of a sync
878 * manager. The \a pdos field of the return value is left empty. Use
879 * ecrt_master_get_pdo() to get the PDO information.
880 *
881 * \apiusage{master_any,blocking}
882 *
883 * \return zero on success, else non-zero
884 */
885 EC_PUBLIC_API int ecrt_master_get_sync_manager(
886     ec_master_t *master, /**< EtherCAT master. */
887     uint16_t slave_position, /**< Slave position. */
888     uint8_t sync_index, /**< Sync manager index. Must be less
889                                     than #EC_MAX_SYNC_MANAGERS. */
890     ec_sync_info_t *sync /**< Pointer to output structure. */
891     );
892
893 /** Returns information about a currently assigned PDO.
894 *
895 * Fills a given ec_pdo_info_t structure with the attributes of a currently

```

```
896 * assigned PDO of the given sync manager. The \a entries field of the return
897 * value is left empty. Use ecrt_master_get_pdo_entry() to get the PDO
898 * entry information.
899 *
900 * \apiusage{master_any,blocking}
901 *
902 * \retval zero on success, else non-zero
903 */
904 EC_PUBLIC_API int ecrt_master_get_pdo(
905     ec_master_t *master, /**< EtherCAT master. */
906     uint16_t slave_position, /**< Slave position. */
907     uint8_t sync_index, /**< Sync manager index. Must be less
908                          than #EC_MAX_SYNC_MANAGERS. */
909     uint16_t pos, /**< Zero-based PDO position. */
910     ec_pdo_info_t *pdo /**< Pointer to output structure. */
911 );
912
913 /** Returns information about a currently mapped PDO entry.
914 *
915 * Fills a given ec_pdo_entry_info_t structure with the attributes of a
916 * currently mapped PDO entry of the given PDO.
917 *
918 * \apiusage{master_any,blocking}
919 *
920 * \retval zero on success, else non-zero
921 */
922 EC_PUBLIC_API int ecrt_master_get_pdo_entry(
923     ec_master_t *master, /**< EtherCAT master. */
924     uint16_t slave_position, /**< Slave position. */
925     uint8_t sync_index, /**< Sync manager index. Must be less
926                          than #EC_MAX_SYNC_MANAGERS. */
927     uint16_t pdo_pos, /**< Zero-based PDO position. */
928     uint16_t entry_pos, /**< Zero-based PDO entry position. */
929     ec_pdo_entry_info_t *entry /**< Pointer to output structure. */
930 );
931
932 #endif /* #ifndef __KERNEL__ */
933
934 /** Executes an SDO download request to write data to a slave.
935 *
936 * This request is processed by the master state machine. This method blocks,
937 * until the request has been processed and may not be called in realtime
938 * context.
939 *
940 * \apiusage{master_any,blocking}
941 *
942 * \retval 0 Success.
943 * \retval <0 Error code.
944 */
945 EC_PUBLIC_API int ecrt_master_sdo_download(
946     ec_master_t *master, /**< EtherCAT master. */
947     uint16_t slave_position, /**< Slave position. */
948     uint16_t index, /**< Index of the SDO. */
949     uint8_t subindex, /**< Subindex of the SDO. */
950     const uint8_t *data, /**< Data buffer to download. */
951     size_t data_size, /**< Size of the data buffer. */
952     uint32_t *abort_code /**< Abort code of the SDO download. */
953 );
954
955 /** Executes an SDO download request to write data to a slave via complete
956 * access.
957 *
958 * This request is processed by the master state machine. This method blocks,
959 * until the request has been processed and may not be called in realtime
960 * context.
961 *
```

```
962 * \apiusage{master_any,blocking}
963 *
964 * \retval 0 Success.
965 * \retval <0 Error code.
966 */
967 EC_PUBLIC_API int ecrt_master_sdo_download_complete(
968     ec_master_t *master, /**< EtherCAT master. */
969     uint16_t slave_position, /**< Slave position. */
970     uint16_t index, /**< Index of the SDO. */
971     const uint8_t *data, /**< Data buffer to download. */
972     size_t data_size, /**< Size of the data buffer. */
973     uint32_t *abort_code /**< Abort code of the SDO download. */
974 );
975
976 /** Executes an SDO upload request to read data from a slave.
977 *
978 * This request is processed by the master state machine. This method blocks,
979 * until the request has been processed and may not be called in realtime
980 * context.
981 *
982 * \apiusage{master_any,blocking}
983 *
984 * \retval 0 Success.
985 * \retval <0 Error code.
986 */
987 EC_PUBLIC_API int ecrt_master_sdo_upload(
988     ec_master_t *master, /**< EtherCAT master. */
989     uint16_t slave_position, /**< Slave position. */
990     uint16_t index, /**< Index of the SDO. */
991     uint8_t subindex, /**< Subindex of the SDO. */
992     uint8_t *target, /**< Target buffer for the upload. */
993     size_t target_size, /**< Size of the target buffer. */
994     size_t *result_size, /**< Uploaded data size. */
995     uint32_t *abort_code /**< Abort code of the SDO upload. */
996 );
997
998 /** Executes an SoE write request.
999 *
1000 * Starts writing an IDN and blocks until the request was processed, or an
1001 * error occurred.
1002 *
1003 * \apiusage{master_any,blocking}
1004 *
1005 * \retval 0 Success.
1006 * \retval <0 Error code.
1007 */
1008 EC_PUBLIC_API int ecrt_master_write_idn(
1009     ec_master_t *master, /**< EtherCAT master. */
1010     uint16_t slave_position, /**< Slave position. */
1011     uint8_t drive_no, /**< Drive number. */
1012     uint16_t idn, /**< SoE IDN (see ecrt_slave_config_idn()). */
1013     const uint8_t *data, /**< Pointer to data to write. */
1014     size_t data_size, /**< Size of data to write. */
1015     uint16_t *error_code /**< Pointer to variable, where an SoE error code
1016                          can be stored. */
1017 );
1018
1019 /** Executes an SoE read request.
1020 *
1021 * Starts reading an IDN and blocks until the request was processed, or an
1022 * error occurred.
1023 *
1024 * \apiusage{master_any,blocking}
1025 *
1026 * \retval 0 Success.
1027 * \retval <0 Error code.
```

```
1028 */
1029 EC_PUBLIC_API int ecrt_master_read_idn(
1030     ec_master_t *master, /**< EtherCAT master. */
1031     uint16_t slave_position, /**< Slave position. */
1032     uint8_t drive_no, /**< Drive number. */
1033     uint16_t idn, /**< SoE IDN (see ecrt_slave_config_idn()). */
1034     uint8_t *target, /**< Pointer to memory where the read data can be
1035                       stored. */
1036     size_t target_size, /**< Size of the memory \a target points to. */
1037     size_t *result_size, /**< Actual size of the received data. */
1038     uint16_t *error_code /**< Pointer to variable, where an SoE error code
1039                           can be stored. */
1040 );
1041
1042 /** Finishes the configuration phase and prepares for cyclic operation.
1043  *
1044  * This function tells the master that the configuration phase is finished and
1045  * the realtime operation will begin. The function allocates internal memory
1046  * for the domains and calculates the logical FMMU addresses for domain
1047  * members. It tells the master state machine that the configuration is
1048  * now to be applied to the network.
1049  *
1050  * \apiusage{master_idle,blocking}
1051  *
1052  * \attention After this function has been called, the realtime application is
1053  * in charge of cyclically calling ecrt_master_send() and
1054  * ecrt_master_receive() to ensure network communication. Before calling this
1055  * function, the master thread is responsible for that, so these functions may
1056  * not be called! The method itself allocates memory and should not be called
1057  * in realtime context.
1058  *
1059  * \return 0 in case of success, else < 0
1060  */
1061 EC_PUBLIC_API int ecrt_master_activate(
1062     ec_master_t *master /**< EtherCAT master. */
1063 );
1064
1065 /** Deactivates the master.
1066  *
1067  * Removes the master configuration. All objects created by
1068  * ecrt_master_create_domain(), ecrt_master_slave_config(), ecrt_domain_data()
1069  * ecrt_slave_config_create_sdo_request() and
1070  * ecrt_slave_config_create_voe_handler() are freed, so pointers to them
1071  * become invalid.
1072  *
1073  * \apiusage{master_op,blocking}
1074  *
1075  * This method should not be called in realtime context.
1076  * \return 0 on success, otherwise negative error code.
1077  * \retval 0 Success.
1078  * \retval -EINVAL Master has not been activated before.
1079  */
1080 EC_PUBLIC_API int ecrt_master_deactivate(
1081     ec_master_t *master /**< EtherCAT master. */
1082 );
1083
1084 /** Set interval between calls to ecrt_master_send().
1085  *
1086  * This information helps the master to decide, how much data can be appended
1087  * to a frame by the master state machine. When the master is configured with
1088  * --enable-hrtimers, this is used to calculate the scheduling of the master
1089  * thread.
1090  *
1091  * \apiusage{master_idle,blocking}
1092  *
1093  * \retval 0 on success.
```



```

1094 * \retval <0 Error code.
1095 */
1096 EC_PUBLIC_API int ecrt_master_set_send_interval(
1097     ec_master_t *master, /**< EtherCAT master. */
1098     size_t send_interval /**< Send interval in us */
1099     );
1100
1101 /** Sends all datagrams in the queue.
1102 *
1103 * This method takes all datagrams, that have been queued for transmission,
1104 * puts them into frames, and passes them to the Ethernet device for sending.
1105 *
1106 * Has to be called cyclically by the application after ecrt_master_activate()
1107 * has returned.
1108 *
1109 * \apiusage{master_op,rt_safe}
1110 *
1111 * \return Zero on success, otherwise negative error code.
1112 */
1113 EC_PUBLIC_API int ecrt_master_send(
1114     ec_master_t *master /**< EtherCAT master. */
1115     );
1116
1117 /** Fetches received frames from the hardware and processes the datagrams.
1118 *
1119 * Queries the network device for received frames by calling the interrupt
1120 * service routine. Extracts received datagrams and dispatches the results to
1121 * the datagram objects in the queue. Received datagrams, and the ones that
1122 * timed out, will be marked, and dequeued.
1123 *
1124 * Has to be called cyclically by the realtime application after
1125 * ecrt_master_activate() has returned.
1126 *
1127 * \apiusage{master_op,rt_safe}
1128 *
1129 * \return Zero on success, otherwise negative error code.
1130 */
1131 EC_PUBLIC_API int ecrt_master_receive(
1132     ec_master_t *master /**< EtherCAT master. */
1133     );
1134
1135 #ifdef __KERNEL__
1136 /** Sends non-application datagrams.
1137 *
1138 * This method has to be called in the send callback function passed via
1139 * ecrt_master_callbacks() to allow the sending of non-application datagrams.
1140 *
1141 * \apiusage{master_op,rt_safe}
1142 *
1143 * \return Zero on success, otherwise negative error code.
1144 * \retval -EAGAIN Lock could not be acquired, try again later.
1145 */
1146 int ecrt_master_send_ext(
1147     ec_master_t *master /**< EtherCAT master. */
1148     );
1149 #endif
1150
1151 /** Reads the current master state.
1152 *
1153 * Stores the master state information in the given \a state structure.
1154 *
1155 * This method returns a global state. For the link-specific states in a
1156 * redundant network topology, use the ecrt_master_link_state() method.
1157 *
1158 * \apiusage{master_any,rt_safe}
1159 *

```

```
1160 * \return Zero on success, otherwise negative error code.
1161 */
1162 EC_PUBLIC_API int ecrt_master_state(
1163     const ec_master_t *master, /**< EtherCAT master. */
1164     ec_master_state_t *state /**< Structure to store the information. */
1165 );
1166
1167 /** Reads the current state of a redundant link.
1168 *
1169 * Stores the link state information in the given \a state structure.
1170 *
1171 * \apiusage{master_any,rt_safe}
1172 *
1173 * \return Zero on success, otherwise negative error code.
1174 */
1175 EC_PUBLIC_API int ecrt_master_link_state(
1176     const ec_master_t *master, /**< EtherCAT master. */
1177     unsigned int dev_idx, /**< Index of the device (0 = main device, 1 =
1178         first backup device, ...). */
1179     ec_master_link_state_t *state /**< Structure to store the information.
1180         */
1181 );
1182
1183 /** Sets the application time.
1184 *
1185 * The master has to know the application's time when operating slaves with
1186 * distributed clocks. The time is not incremented by the master itself, so
1187 * this method has to be called cyclically.
1188 *
1189 * \attention The time passed to this method is used to calculate the phase of
1190 * the slaves' SYNC0/1 interrupts. It should be called constantly at the same
1191 * point of the realtime cycle. So it is recommended to call it at the start
1192 * of the calculations to avoid deviancies due to changing execution times.
1193 * Avoid calling this method before the realtime cycle is established.
1194 *
1195 * The time is used when setting the slaves' <tt>System Time Offset</tt> and
1196 * <tt>Cyclic Operation Start Time</tt> registers and when synchronizing the
1197 * DC reference clock to the application time via
1198 * ecrt_master_sync_reference_clock().
1199 *
1200 * The time is defined as nanoseconds from 2000-01-01 00:00. Converting an
1201 * epoch time can be done with the EC_TIMEVAL2NANO() macro, but is not
1202 * necessary, since the absolute value is not of any interest.
1203 *
1204 * \apiusage{master_op,rt_safe}
1205 *
1206 * \return Zero on success, otherwise negative error code.
1207 */
1208 EC_PUBLIC_API int ecrt_master_application_time(
1209     ec_master_t *master, /**< EtherCAT master. */
1210     uint64_t app_time /**< Application time. */
1211 );
1212
1213 /** Queues the DC reference clock drift compensation datagram for sending.
1214 *
1215 * The reference clock will by synchronized to the application time provided
1216 * by the last call off ecrt_master_application_time().
1217 *
1218 * \apiusage{master_op,rt_safe}
1219 *
1220 * \return Zero on success, otherwise negative error code.
1221 * \retval 0 Success.
1222 * \retval -ENXIO No reference clock found.
1223 */
1224 EC_PUBLIC_API int ecrt_master_sync_reference_clock(
1225     ec_master_t *master /**< EtherCAT master. */
```

```

1226     );
1227
1228 /** Queues the DC reference clock drift compensation datagram for sending.
1229  *
1230  * The reference clock will by synchronized to the time passed in the
1231  * sync_time parameter.
1232  *
1233  * Has to be called by the application after ecrt_master_activate()
1234  * has returned.
1235  *
1236  * \apiusage{master_op,rt_safe}
1237  *
1238  * \return Zero on success, otherwise negative error code.
1239  * \retval 0 Success.
1240  * \retval -ENXIO No reference clock found.
1241  */
1242 EC_PUBLIC_API int ecrt_master_sync_reference_clock_to(
1243     ec_master_t *master, /**< EtherCAT master. */
1244     uint64_t sync_time /**< Sync reference clock to this time. */
1245 );
1246
1247 /** Queues the DC clock drift compensation datagram for sending.
1248  *
1249  * All slave clocks synchronized to the reference clock.
1250  *
1251  * Has to be called by the application after ecrt_master_activate()
1252  * has returned.
1253  *
1254  * \apiusage{master_op,rt_safe}
1255  *
1256  * \return 0 on success, otherwise negative error code.
1257  * \retval 0 Success.
1258  * \retval -ENXIO No reference clock found.
1259  */
1260 EC_PUBLIC_API int ecrt_master_sync_slave_clocks(
1261     ec_master_t *master /**< EtherCAT master. */
1262 );
1263
1264 /** Get the lower 32 bit of the reference clock system time.
1265  *
1266  * This method can be used to synchronize the master to the reference clock.
1267  *
1268  * The reference clock system time is queried via the
1269  * ecrt_master_sync_slave_clocks() method, that reads the system time of the
1270  * reference clock and writes it to the slave clocks (so be sure to call it
1271  * cyclically to get valid data).
1272  *
1273  * \attention The returned time is the system time of the reference clock
1274  * minus the transmission delay of the reference clock.
1275  *
1276  * Calling this method makes only sense in realtime context (after master
1277  * activation), when the ecrt_master_sync_slave_clocks() method is called
1278  * cyclically.
1279  *
1280  * \apiusage{master_op,rt_safe}
1281  *
1282  * \retval 0 success, system time was written into \a time.
1283  * \retval -ENXIO No reference clock found.
1284  * \retval -EIO Slave synchronization datagram was not received.
1285  */
1286 EC_PUBLIC_API int ecrt_master_reference_clock_time(
1287     const ec_master_t *master, /**< EtherCAT master. */
1288     uint32_t *time /**< Pointer to store the queried system time. */
1289 );
1290
1291 /** Queues the DC synchrony monitoring datagram for sending.

```

```
1292 *
1293 * The datagram broadcast-reads all "System time difference" registers (\a
1294 * 0x092c) to get an upper estimation of the DC synchrony. The result can be
1295 * checked with the ecrt_master_sync_monitor_process() method.
1296 *
1297 * \apiusage{master_op,rt_safe}
1298 *
1299 * \return Zero on success, otherwise a negative error code.
1300 */
1301 EC_PUBLIC_API int ecrt_master_sync_monitor_queue(
1302     ec_master_t *master /**< EtherCAT master. */
1303 );
1304
1305 /** Processes the DC synchrony monitoring datagram.
1306 *
1307 * If the sync monitoring datagram was sent before with
1308 * ecrt_master_sync_monitor_queue(), the result can be queried with this
1309 * method.
1310 *
1311 * \apiusage{master_op,rt_safe}
1312 *
1313 * \return Upper estimation of the maximum time difference in ns, -1 on error.
1314 * \retval (uint32_t)-1 Error.
1315 */
1316 EC_PUBLIC_API uint32_t ecrt_master_sync_monitor_process(
1317     const ec_master_t *master /**< EtherCAT master. */
1318 );
1319
1320 /** Retry configuring slaves.
1321 *
1322 * Via this method, the application can tell the master to bring all slaves to
1323 * OP state. In general, this is not necessary, because it is automatically
1324 * done by the master. But with special slaves, that can be reconfigured by
1325 * the vendor during runtime, it can be useful.
1326 *
1327 * Calling this method only makes sense in realtime context (after
1328 * activation), because slaves will not be configured before.
1329 *
1330 * \apiusage{master_op,rt_safe}
1331 *
1332 * \return 0 on success, otherwise negative error code.
1333 */
1334 EC_PUBLIC_API int ecrt_master_reset(
1335     ec_master_t *master /**< EtherCAT master. */
1336 );
1337
1338 /*****
1339 * Slave configuration methods
1340 *****/
1341
1342 /** Configure a sync manager.
1343 *
1344 * Sets the direction of a sync manager. This overrides the direction bits
1345 * from the default control register from SII.
1346 *
1347 * This method has to be called in non-realtime context before
1348 * ecrt_master_activate().
1349 *
1350 * \apiusage{master_idle,blocking}
1351 *
1352 * \return zero on success, else non-zero
1353 */
1354 EC_PUBLIC_API int ecrt_slave_config_sync_manager(
1355     ec_slave_config_t *sc, /**< Slave configuration. */
1356     uint8_t sync_index, /**< Sync manager index. Must be less
1357         than #EC_MAX_SYNC_MANAGERS. */
```

```

1358     ec_direction_t direction, /**< Input/Output. */
1359     ec_watchdog_mode_t watchdog_mode /** Watchdog mode. */
1360     );
1361
1362 /** Configure a slave's watchdog times.
1363  *
1364  * This method has to be called in non-realtime context before
1365  * ecrt_master_activate().
1366  *
1367  * \apiusage{master_idle,blocking}
1368  *
1369  * \return 0 on success, otherwise negative error code.
1370  */
1371 EC_PUBLIC_API int ecrt_slave_config_watchdog(
1372     ec_slave_config_t *sc, /**< Slave configuration. */
1373     uint16_t watchdog_divider, /**< Number of 40 ns intervals (register
1374                                0x0400). Used as a base unit for all
1375                                slave watchdogs^. If set to zero, the
1376                                value is not written, so the default is
1377                                used. */
1378     uint16_t watchdog_intervals /**< Number of base intervals for sync
1379                                  manager watchdog (register 0x0420). If
1380                                  set to zero, the value is not written,
1381                                  so the default is used. */
1382     );
1383
1384 /** Add a PDO to a sync manager's PDO assignment.
1385  *
1386  * This method has to be called in non-realtime context before
1387  * ecrt_master_activate().
1388  *
1389  * \apiusage{master_idle,blocking}
1390  *
1391  * \see ecrt_slave_config_pdos()
1392  * \return zero on success, else non-zero
1393  */
1394 EC_PUBLIC_API int ecrt_slave_config_pdo_assign_add(
1395     ec_slave_config_t *sc, /**< Slave configuration. */
1396     uint8_t sync_index, /**< Sync manager index. Must be less
1397                          than #EC_MAX_SYNC_MANAGERS. */
1398     uint16_t index /**< Index of the PDO to assign. */
1399     );
1400
1401 /** Clear a sync manager's PDO assignment.
1402  *
1403  * This can be called before assigning PDOs via
1404  * ecrt_slave_config_pdo_assign_add(), to clear the default assignment of a
1405  * sync manager.
1406  *
1407  * This method has to be called in non-realtime context before
1408  * ecrt_master_activate().
1409  *
1410  * \apiusage{master_idle,blocking}
1411  *
1412  * \see ecrt_slave_config_pdos()
1413  * \return 0 on success, otherwise negative error code.
1414  */
1415 EC_PUBLIC_API int ecrt_slave_config_pdo_assign_clear(
1416     ec_slave_config_t *sc, /**< Slave configuration. */
1417     uint8_t sync_index /**< Sync manager index. Must be less
1418                          than #EC_MAX_SYNC_MANAGERS. */
1419     );
1420
1421 /** Add a PDO entry to the given PDO's mapping.
1422  *
1423  * This method has to be called in non-realtime context before

```

```

1424 * ecrt_master_activate().
1425 *
1426 * \apiusage{master_idle,blocking}
1427 *
1428 * \see ecrt_slave_config_pdos()
1429 * \return zero on success, else non-zero
1430 */
1431 EC_PUBLIC_API int ecrt_slave_config_pdo_mapping_add(
1432     ec_slave_config_t *sc, /**< Slave configuration. */
1433     uint16_t pdo_index, /**< Index of the PDO. */
1434     uint16_t entry_index, /**< Index of the PDO entry to add to the PDO's
1435                             mapping. */
1436     uint8_t entry_subindex, /**< Subindex of the PDO entry to add to the
1437                             PDO's mapping. */
1438     uint8_t entry_bit_length /**< Size of the PDO entry in bit. */
1439 );
1440
1441 /** Clear the mapping of a given PDO.
1442 *
1443 * This can be called before mapping PDO entries via
1444 * ecrt_slave_config_pdo_mapping_add(), to clear the default mapping.
1445 *
1446 * This method has to be called in non-realtime context before
1447 * ecrt_master_activate().
1448 *
1449 * \apiusage{master_idle,blocking}
1450 *
1451 * \see ecrt_slave_config_pdos()
1452 * \return 0 on success, otherwise negative error code.
1453 */
1454 EC_PUBLIC_API int ecrt_slave_config_pdo_mapping_clear(
1455     ec_slave_config_t *sc, /**< Slave configuration. */
1456     uint16_t pdo_index /**< Index of the PDO. */
1457 );
1458
1459 /** Specify a complete PDO configuration.
1460 *
1461 * This function is a convenience wrapper for the functions
1462 * ecrt_slave_config_sync_manager(), ecrt_slave_config_pdo_assign_clear(),
1463 * ecrt_slave_config_pdo_assign_add(), ecrt_slave_config_pdo_mapping_clear()
1464 * and ecrt_slave_config_pdo_mapping_add(), that are better suitable for
1465 * automatic code generation.
1466 *
1467 * The following example shows, how to specify a complete configuration,
1468 * including the PDO mappings. With this information, the master is able to
1469 * reserve the complete process data, even if the slave is not present at
1470 * configuration time:
1471 *
1472 * \code
1473 * ec_pdo_entry_info_t el3162_channel1[] = {
1474 *     {0x3101, 1, 8}, // status
1475 *     {0x3101, 2, 16} // value
1476 * };
1477 *
1478 * ec_pdo_entry_info_t el3162_channel2[] = {
1479 *     {0x3102, 1, 8}, // status
1480 *     {0x3102, 2, 16} // value
1481 * };
1482 *
1483 * ec_pdo_info_t el3162_pdos[] = {
1484 *     {0x1A00, 2, el3162_channel1},
1485 *     {0x1A01, 2, el3162_channel2}
1486 * };
1487 *
1488 * ec_sync_info_t el3162_syncs[] = {
1489 *     {2, EC_DIR_OUTPUT},

```

```

1490 *     {3, EC_DIR_INPUT, 2, e13162_pdos},
1491 *     {0xff}
1492 * };
1493 *
1494 * if (ecrt_slave_config_pdos(sc_ana_in, EC_END, e13162_syncs)) {
1495 *     // handle error
1496 * }
1497 * \endcode
1498 *
1499 * The next example shows, how to configure the PDO assignment only. The
1500 * entries for each assigned PDO are taken from the PDO's default mapping.
1501 * Please note, that PDO entry registration will fail, if the PDO
1502 * configuration is left empty and the slave is offline.
1503 *
1504 * \code
1505 * ec_pdo_info_t pdos[] = {
1506 *     {0x1600}, // Channel 1
1507 *     {0x1601} // Channel 2
1508 * };
1509 *
1510 * ec_sync_info_t syncs[] = {
1511 *     {3, EC_DIR_INPUT, 2, pdos},
1512 * };
1513 *
1514 * if (ecrt_slave_config_pdos(slave_config_ana_in, 1, syncs)) {
1515 *     // handle error
1516 * }
1517 * \endcode
1518 *
1519 * Processing of \a syncs will stop, if
1520 * - the number of processed items reaches \a n_syncs, or
1521 * - the \a index member of an ec_sync_info_t item is 0xff. In this case,
1522 *   \a n_syncs should set to a number greater than the number of list items;
1523 *   using EC_END is recommended.
1524 *
1525 * This method has to be called in non-realtime context before
1526 * ecrt_master_activate().
1527 *
1528 * \apiusage{master_idle,blocking}
1529 *
1530 * \return zero on success, else non-zero
1531 */
1532 EC_PUBLIC_API int ecrt_slave_config_pdos(
1533     ec_slave_config_t *sc, /**< Slave configuration. */
1534     unsigned int n_syncs, /**< Number of sync manager configurations in
1535                          \a syncs. */
1536     const ec_sync_info_t syncs[] /**< Array of sync manager
1537                                   configurations. */
1538     );
1539
1540 /** Registers a PDO entry for process data exchange in a domain.
1541 *
1542 * Searches the assigned PDOs for the given PDO entry. An error is raised, if
1543 * the given entry is not mapped. Otherwise, the corresponding sync manager
1544 * and FMMU configurations are provided for slave configuration and the
1545 * respective sync manager's assigned PDOs are appended to the given domain,
1546 * if not already done. The offset of the requested PDO entry's data inside
1547 * the domain's process data is returned. Optionally, the PDO entry bit
1548 * position (0-7) can be retrieved via the \a bit_position output parameter.
1549 * This pointer may be \a NULL, in this case an error is raised if the PDO
1550 * entry does not byte-align.
1551 *
1552 * This method has to be called in non-realtime context before
1553 * ecrt_master_activate().
1554 *
1555 * \apiusage{master_idle,blocking}

```

```
1556 *
1557 * \retval >=0 Success: Offset of the PDO entry's process data.
1558 * \retval <0 Error code.
1559 */
1560 EC_PUBLIC_API int ecrt_slave_config_reg_pdo_entry(
1561     ec_slave_config_t *sc, /**< Slave configuration. */
1562     uint16_t entry_index, /**< Index of the PDO entry to register. */
1563     uint8_t entry_subindex, /**< Subindex of the PDO entry to register. */
1564     ec_domain_t *domain, /**< Domain. */
1565     unsigned int *bit_position /**< Optional address if bit addressing
1566                               is desired */
1567 );
1568
1569 /** Registers a PDO entry using its position.
1570 *
1571 * Similar to ecrt_slave_config_reg_pdo_entry(), but not using PDO indices but
1572 * offsets in the PDO mapping, because PDO entry indices may not be unique
1573 * inside a slave's PDO mapping. An error is raised, if
1574 * one of the given positions is out of range.
1575 *
1576 * This method has to be called in non-realtime context before
1577 * ecrt_master_activate().
1578 *
1579 * \apiusage{master_idle,blocking}
1580 *
1581 * \retval >=0 Success: Offset of the PDO entry's process data.
1582 * \retval <0 Error code.
1583 */
1584 EC_PUBLIC_API int ecrt_slave_config_reg_pdo_entry_pos(
1585     ec_slave_config_t *sc, /**< Slave configuration. */
1586     uint8_t sync_index, /**< Sync manager index. */
1587     unsigned int pdo_pos, /**< Position of the PDO inside the SM. */
1588     unsigned int entry_pos, /**< Position of the entry inside the PDO. */
1589     ec_domain_t *domain, /**< Domain. */
1590     unsigned int *bit_position /**< Optional address if bit addressing
1591                               is desired */
1592 );
1593
1594 /** Configure distributed clocks.
1595 *
1596 * Sets the AssignActivate word and the cycle and shift times for the sync
1597 * signals.
1598 *
1599 * The AssignActivate word is vendor-specific and can be taken from the XML
1600 * device description file (Device -> Dc -> AssignActivate). Set this to zero,
1601 * if the slave shall be operated without distributed clocks (default).
1602 *
1603 * This method has to be called in non-realtime context before
1604 * ecrt_master_activate().
1605 *
1606 * \apiusage{master_idle,blocking}
1607 *
1608 * \attention The \a sync1_shift time is ignored.
1609 * \return 0 on success, otherwise negative error code.
1610 */
1611 EC_PUBLIC_API int ecrt_slave_config_dc(
1612     ec_slave_config_t *sc, /**< Slave configuration. */
1613     uint16_t assign_activate, /**< AssignActivate word. */
1614     uint32_t sync0_cycle, /**< SYNC0 cycle time [ns]. */
1615     int32_t sync0_shift, /**< SYNC0 shift time [ns]. */
1616     uint32_t sync1_cycle, /**< SYNC1 cycle time [ns]. */
1617     int32_t sync1_shift /**< SYNC1 shift time [ns]. */
1618 );
1619
1620 /** Add an SDO configuration.
1621 *
```



```

1622 * An SDO configuration is stored in the slave configuration object and is
1623 * downloaded to the slave whenever the slave is being configured by the
1624 * master. This usually happens once on master activation, but can be repeated
1625 * subsequently, for example after the slave's power supply failed.
1626 *
1627 * \attention The SDOs for PDO assignment (\p 0x1C10 - \p 0x1C2F) and PDO
1628 * mapping (\p 0x1600 - \p 0x17FF and \p 0x1A00 - \p 0x1BFF) should not be
1629 * configured with this function, because they are part of the slave
1630 * configuration done by the master. Please use ecrt_slave_config_pdos() and
1631 * friends instead.
1632 *
1633 * This is the generic function for adding an SDO configuration. Please note
1634 * that the this function does not do any endianness correction. If
1635 * datatype-specific functions are needed (that automatically correct the
1636 * endianness), have a look at ecrt_slave_config_sdo8(),
1637 * ecrt_slave_config_sdo16() and ecrt_slave_config_sdo32().
1638 *
1639 * This method has to be called in non-realtime context before
1640 * ecrt_master_activate().
1641 *
1642 * \apiusage{master_idle,blocking}
1643 *
1644 * \retval 0 Success.
1645 * \retval <0 Error code.
1646 */
1647 EC_PUBLIC_API int ecrt_slave_config_sdo(
1648     ec_slave_config_t *sc, /**< Slave configuration. */
1649     uint16_t index, /**< Index of the SDO to configure. */
1650     uint8_t subindex, /**< Subindex of the SDO to configure. */
1651     const uint8_t *data, /**< Pointer to the data. */
1652     size_t size /**< Size of the \a data. */
1653     );
1654
1655 /** Add a configuration value for an 8-bit SDO.
1656 *
1657 * This method has to be called in non-realtime context before
1658 * ecrt_master_activate().
1659 *
1660 * \see ecrt_slave_config_sdo().
1661 *
1662 * \apiusage{master_idle,blocking}
1663 *
1664 * \retval 0 Success.
1665 * \retval <0 Error code.
1666 */
1667 EC_PUBLIC_API int ecrt_slave_config_sdo8(
1668     ec_slave_config_t *sc, /**< Slave configuration */
1669     uint16_t sdo_index, /**< Index of the SDO to configure. */
1670     uint8_t sdo_subindex, /**< Subindex of the SDO to configure. */
1671     uint8_t value /**< Value to set. */
1672     );
1673
1674 /** Add a configuration value for a 16-bit SDO.
1675 *
1676 * This method has to be called in non-realtime context before
1677 * ecrt_master_activate().
1678 *
1679 * \see ecrt_slave_config_sdo().
1680 *
1681 * \apiusage{master_idle,blocking}
1682 *
1683 * \retval 0 Success.
1684 * \retval <0 Error code.
1685 */
1686 EC_PUBLIC_API int ecrt_slave_config_sdo16(
1687     ec_slave_config_t *sc, /**< Slave configuration */

```

```
1688     uint16_t sdo_index, /**< Index of the SDO to configure. */
1689     uint8_t sdo_subindex, /**< Subindex of the SDO to configure. */
1690     uint16_t value /**< Value to set. */
1691 );
1692
1693 /** Add a configuration value for a 32-bit SDO.
1694  *
1695  * This method has to be called in non-realtime context before
1696  * ecrt_master_activate().
1697  *
1698  * \see ecrt_slave_config_sdo().
1699  *
1700  * \apiusage{master_idle,blocking}
1701  *
1702  * \retval 0 Success.
1703  * \retval <0 Error code.
1704  */
1705 EC_PUBLIC_API int ecrt_slave_config_sdo32(
1706     ec_slave_config_t *sc, /**< Slave configuration */
1707     uint16_t sdo_index, /**< Index of the SDO to configure. */
1708     uint8_t sdo_subindex, /**< Subindex of the SDO to configure. */
1709     uint32_t value /**< Value to set. */
1710 );
1711
1712 /** Add configuration data for a complete SDO.
1713  *
1714  * The SDO data are transferred via CompleteAccess. Data for the first
1715  * subindex (0) have to be included.
1716  *
1717  * This method has to be called in non-realtime context before
1718  * ecrt_master_activate().
1719  *
1720  * \see ecrt_slave_config_sdo().
1721  *
1722  * \apiusage{master_idle,blocking}
1723  *
1724  * \retval 0 Success.
1725  * \retval <0 Error code.
1726  */
1727 EC_PUBLIC_API int ecrt_slave_config_complete_sdo(
1728     ec_slave_config_t *sc, /**< Slave configuration. */
1729     uint16_t index, /**< Index of the SDO to configure. */
1730     const uint8_t *data, /**< Pointer to the data. */
1731     size_t size /**< Size of the \a data. */
1732 );
1733
1734 /** Set the size of the CoE emergency ring buffer.
1735  *
1736  * The initial size is zero, so all messages will be dropped. This method can
1737  * be called even after master activation, but it will clear the ring buffer!
1738  *
1739  * This method has to be called in non-realtime context before
1740  * ecrt_master_activate().
1741  *
1742  * \apiusage{master_idle,blocking}
1743  *
1744  * \return 0 on success, or negative error code.
1745  */
1746 EC_PUBLIC_API int ecrt_slave_config_emerg_size(
1747     ec_slave_config_t *sc, /**< Slave configuration. */
1748     size_t elements /**< Number of records of the CoE emergency ring. */
1749 );
1750
1751 /** Read and remove one record from the CoE emergency ring buffer.
1752  *
1753  * A record consists of 8 bytes:
```

```

1754  *
1755  * Byte 0-1: Error code (little endian)
1756  * Byte 2: Error register
1757  * Byte 3-7: Data
1758  *
1759  * Calling this method makes only sense in realtime context (after master
1760  * activation).
1761  *
1762  * \return 0 on success (record popped), or negative error code (i. e.
1763  * -ENOENT, if ring is empty).
1764  *
1765  * \apiusage{master_op,any_context}
1766  */
1767 EC_PUBLIC_API int ecrt_slave_config_emerg_pop(
1768     ec_slave_config_t *sc, /**< Slave configuration. */
1769     uint8_t *target /**< Pointer to target memory (at least
1770                    EC_COE_EMERGENCY_MSG_SIZE bytes). */
1771     );
1772
1773 /** Clears CoE emergency ring buffer and the overrun counter.
1774  *
1775  * Calling this method makes only sense in realtime context (after master
1776  * activation).
1777  *
1778  * \apiusage{master_op,any_context}
1779  *
1780  * \return 0 on success, or negative error code.
1781  *
1782  */
1783 EC_PUBLIC_API int ecrt_slave_config_emerg_clear(
1784     ec_slave_config_t *sc /**< Slave configuration. */
1785     );
1786
1787 /** Read the number of CoE emergency overruns.
1788  *
1789  * The overrun counter will be incremented when a CoE emergency message could
1790  * not be stored in the ring buffer and had to be dropped. Call
1791  * ecrt_slave_config_emerg_clear() to reset the counter.
1792  *
1793  * Calling this method makes only sense in realtime context (after master
1794  * activation).
1795  *
1796  * \apiusage{master_op,any_context}
1797  *
1798  * \return Number of overruns since last clear, or negative error code.
1799  *
1800  */
1801 EC_PUBLIC_API int ecrt_slave_config_emerg_overruns(
1802     const ec_slave_config_t *sc /**< Slave configuration. */
1803     );
1804
1805 /** Create an SDO request to exchange SDOs during realtime operation.
1806  *
1807  * The created SDO request object is freed automatically when the master is
1808  * released.
1809  *
1810  * This method has to be called in non-realtime context before
1811  * ecrt_master_activate().
1812  *
1813  * \apiusage{master_idle,blocking}
1814  *
1815  * \return New SDO request, or NULL on error.
1816  */
1817 EC_PUBLIC_API ec_sdo_request_t *ecrt_slave_config_create_sdo_request(
1818     ec_slave_config_t *sc, /**< Slave configuration. */
1819     uint16_t index, /**< SDO index. */

```

```

1820         uint8_t subindex, /**< SDO subindex. */
1821         size_t size /**< Data size to reserve. */
1822     );
1823
1824 /** Create an SoE request to exchange SoE IDNs during realtime operation.
1825  *
1826  * The created SoE request object is freed automatically when the master is
1827  * released.
1828  *
1829  * This method has to be called in non-realtime context before
1830  * ecrt_master_activate().
1831  *
1832  * \apiusage{master_idle,blocking}
1833  *
1834  * \return New SoE request, or NULL on error.
1835  */
1836 EC_PUBLIC_API ec_soe_request_t *ecrt_slave_config_create_soe_request(
1837     ec_slave_config_t *sc, /**< Slave configuration. */
1838     uint8_t drive_no, /**< Drive number. */
1839     uint16_t idn, /**< Sercos ID-Number. */
1840     size_t size /**< Data size to reserve. */
1841 );
1842
1843 /** Create an VoE handler to exchange vendor-specific data during realtime
1844  * operation.
1845  *
1846  * The number of VoE handlers per slave configuration is not limited, but
1847  * usually it is enough to create one for sending and one for receiving, if
1848  * both can be done simultaneously.
1849  *
1850  * The created VoE handler object is freed automatically when the master is
1851  * released.
1852  *
1853  * This method has to be called in non-realtime context before
1854  * ecrt_master_activate().
1855  *
1856  * \apiusage{master_idle,blocking}
1857  *
1858  * \return New VoE handler, or NULL on error.
1859  */
1860 EC_PUBLIC_API ec_voe_handler_t *ecrt_slave_config_create_voe_handler(
1861     ec_slave_config_t *sc, /**< Slave configuration. */
1862     size_t size /**< Data size to reserve. */
1863 );
1864
1865 /** Create a register request to exchange EtherCAT register contents during
1866  * realtime operation.
1867  *
1868  * This interface should not be used to take over master functionality,
1869  * instead it is intended for debugging and monitoring reasons.
1870  *
1871  * The created register request object is freed automatically when the master
1872  * is released.
1873  *
1874  * This method has to be called in non-realtime context before
1875  * ecrt_master_activate().
1876  *
1877  * \apiusage{master_idle,blocking}
1878  *
1879  * \return New register request, or NULL on error.
1880  */
1881 EC_PUBLIC_API ec_reg_request_t *ecrt_slave_config_create_reg_request(
1882     ec_slave_config_t *sc, /**< Slave configuration. */
1883     size_t size /**< Data size to reserve. */
1884 );
1885

```

```

1886 /** Outputs the state of the slave configuration.
1887  *
1888  * Stores the state information in the given \a state structure. The state
1889  * information is updated by the master state machine, so it may take a few
1890  * cycles, until it changes.
1891  *
1892  * \attention If the state of process data exchange shall be monitored in
1893  * realtime, ecrt_domain_state() should be used.
1894  *
1895  * \apiusage{master_op,rt_safe}
1896  *
1897  * This method is meant to be called in realtime context (after master
1898  * activation).
1899  *
1900  * \retval 0 Success.
1901  * \retval <0 Error code.
1902  */
1903 EC_PUBLIC_API int ecrt_slave_config_state(
1904     const ec_slave_config_t *sc, /**< Slave configuration */
1905     ec_slave_config_state_t *state /**< State object to write to. */
1906     );
1907
1908 /** Add an SoE IDN configuration.
1909  *
1910  * A configuration for a Sercos-over-EtherCAT IDN is stored in the slave
1911  * configuration object and is written to the slave whenever the slave is
1912  * being configured by the master. This usually happens once on master
1913  * activation, but can be repeated subsequently, for example after the slave's
1914  * power supply failed.
1915  *
1916  * The \a idn parameter can be separated into several sections:
1917  * - Bit 15: Standard data (0) or Product data (1)
1918  * - Bit 14 - 12: Parameter set (0 - 7)
1919  * - Bit 11 - 0: Data block number (0 - 4095)
1920  *
1921  * Please note that the this function does not do any endianness correction.
1922  * Multi-byte data have to be passed in EtherCAT endianness (little-endian).
1923  *
1924  * This method has to be called in non-realtime context before
1925  * ecrt_master_activate().
1926  *
1927  * \apiusage{master_idle,blocking}
1928  *
1929  * \retval 0 Success.
1930  * \retval <0 Error code.
1931  */
1932 EC_PUBLIC_API int ecrt_slave_config_idn(
1933     ec_slave_config_t *sc, /**< Slave configuration. */
1934     uint8_t drive_no, /**< Drive number. */
1935     uint16_t idn, /**< SoE IDN. */
1936     ec_al_state_t state, /**< AL state in which to write the IDN (PREOP or
1937     SAFEOP). */
1938     const uint8_t *data, /**< Pointer to the data. */
1939     size_t size /**< Size of the \a data. */
1940     );
1941
1942 /** Adds a feature flag to a slave configuration.
1943  *
1944  * Feature flags are a generic way to configure slave-specific behavior.
1945  *
1946  * Multiple calls with the same slave configuration and key will overwrite the
1947  * configuration.
1948  *
1949  * The following flags may be available:
1950  * - AssignToPdi: Zero (default) keeps the slave information interface (SII)
1951  *   assigned to EtherCAT (except during transition to PREOP). Non-zero

```

```

1952 *   assigns the SII to the slave controller side before going to PREOP and
1953 *   leaves it there until a write command happens.
1954 * - WaitBeforeSAFEOPms: Number of milliseconds to wait before commanding the
1955 *   transition from PREOP to SAFEOP. This can be used as a workaround for
1956 *   slaves that need a little time to initialize.
1957 *
1958 * This method has to be called in non-realtime context before
1959 * ecrt_master_activate().
1960 *
1961 * \apiusage{master_idle,blocking}
1962 *
1963 * \retval 0 Success.
1964 * \retval <0 Error code.
1965 */
1966 EC_PUBLIC_API int ecrt_slave_config_flag(
1967     ec_slave_config_t *sc, /**< Slave configuration. */
1968     const char *key, /**< Key as null-terminated ASCII string. */
1969     int32_t value /**< Value to store. */
1970 );
1971
1972 /** Sets the link/MAC address for Ethernet-over-EtherCAT (EoE) operation.
1973 *
1974 * This method has to be called in non-realtime context before
1975 * ecrt_master_activate().
1976 *
1977 * The MAC address is stored in the slave configuration object and will be
1978 * written to the slave during the configuration process.
1979 *
1980 * \apiusage{master_idle,blocking}
1981 *
1982 * \retval 0 Success.
1983 * \retval <0 Error code.
1984 */
1985 EC_PUBLIC_API int ecrt_slave_config_eoe_mac_address(
1986     ec_slave_config_t *sc, /**< Slave configuration. */
1987     const unsigned char *mac_address /**< MAC address. */
1988 );
1989
1990 /** Sets the IP address for Ethernet-over-EtherCAT (EoE) operation.
1991 *
1992 * This method has to be called in non-realtime context before
1993 * ecrt_master_activate().
1994 *
1995 * The IP address is stored in the slave configuration object and will be
1996 * written to the slave during the configuration process.
1997 *
1998 * The IP address is passed by-value as a 'struct in_addr'. This structure
1999 * contains the 32-bit IPv4 address in network byte order (big endian).
2000 *
2001 * A string-represented IPv4 address can be converted to a 'struct in_addr'
2002 * for example via the POSIX function 'inet_pton()' (see man 3 inet_pton):
2003 *
2004 * \code{.c}
2005 *   #include <arpa/inet.h>
2006 *   struct in_addr addr;
2007 *   if (inet_aton("192.168.0.1", &addr) == 0) {
2008 *       fprintf(stderr, "Failed to convert IP address.\n");
2009 *       return -1;
2010 *   }
2011 *   if (ecrt_slave_config_eoe_ip_address(sc, addr)) {
2012 *       fprintf(stderr, "Failed to set IP address.\n");
2013 *       return -1;
2014 *   }
2015 * \endcode
2016 *
2017 *

```

```

2018 * \apiusage{master_idle,blocking}
2019 *
2020 * \retval 0 Success.
2021 * \retval <0 Error code.
2022 */
2023 EC_PUBLIC_API int ecrt_slave_config_eoe_ip_address(
2024     ec_slave_config_t *sc, /**< Slave configuration. */
2025     struct in_addr ip_address /**< IPv4 address. */
2026     );
2027
2028 /** Sets the subnet mask for Ethernet-over-EtherCAT (EoE) operation.
2029 *
2030 * This method has to be called in non-realtime context before
2031 * ecrt_master_activate().
2032 *
2033 * The subnet mask is stored in the slave configuration object and will be
2034 * written to the slave during the configuration process.
2035 *
2036 * The subnet mask is passed by-value as a 'struct in_addr'. This structure
2037 * contains the 32-bit mask in network byte order (big endian).
2038 *
2039 * See ecrt_slave_config_eoe_ip_address() on how to convert string-coded masks
2040 * to 'struct in_addr'.
2041 *
2042 * \apiusage{master_idle,blocking}
2043 *
2044 * \retval 0 Success.
2045 * \retval <0 Error code.
2046 */
2047 EC_PUBLIC_API int ecrt_slave_config_eoe_subnet_mask(
2048     ec_slave_config_t *sc, /**< Slave configuration. */
2049     struct in_addr subnet_mask /**< IPv4 subnet mask. */
2050     );
2051
2052 /** Sets the gateway address for Ethernet-over-EtherCAT (EoE) operation.
2053 *
2054 * This method has to be called in non-realtime context before
2055 * ecrt_master_activate().
2056 *
2057 * The gateway address is stored in the slave configuration object and will be
2058 * written to the slave during the configuration process.
2059 *
2060 * The address is passed by-value as a 'struct in_addr'. This structure
2061 * contains the 32-bit IPv4 address in network byte order (big endian).
2062 *
2063 * See ecrt_slave_config_eoe_ip_address() on how to convert string-coded IPv4
2064 * addresses to 'struct in_addr'.
2065 *
2066 * \apiusage{master_idle,blocking}
2067 *
2068 * \retval 0 Success.
2069 * \retval <0 Error code.
2070 */
2071 EC_PUBLIC_API int ecrt_slave_config_eoe_default_gateway(
2072     ec_slave_config_t *sc, /**< Slave configuration. */
2073     struct in_addr gateway_address /**< Gateway's IPv4 address. */
2074     );
2075
2076 /** Sets the IPv4 address of the DNS server for Ethernet-over-EtherCAT (EoE)
2077 * operation.
2078 *
2079 * This method has to be called in non-realtime context before
2080 * ecrt_master_activate().
2081 *
2082 * The DNS server address is stored in the slave configuration object and will
2083 * be written to the slave during the configuration process.

```

```

2084 *
2085 * The address is passed by-value as a 'struct in_addr'. This structure
2086 * contains the 32-bit IPv4 address in network byte order (big endian).
2087 *
2088 * See ecrt_slave_config_eoe_ip_address() on how to convert string-coded IPv4
2089 * addresses to 'struct in_addr'.
2090 *
2091 * \apiusage{master_idle,blocking}
2092 *
2093 * \retval 0 Success.
2094 * \retval <0 Error code.
2095 */
2096 EC_PUBLIC_API int ecrt_slave_config_eoe_dns_address(
2097     ec_slave_config_t *sc, /**< Slave configuration. */
2098     struct in_addr dns_address /**< IPv4 address of the DNS server. */
2099 );
2100
2101 /** Sets the host name for Ethernet-over-EtherCAT (EoE) operation.
2102 *
2103 * This method has to be called in non-realtime context before
2104 * ecrt_master_activate().
2105 *
2106 * The host name is stored in the slave configuration object and will
2107 * be written to the slave during the configuration process.
2108 *
2109 * The maximum size of the host name is 32 bytes (including the zero
2110 * terminator).
2111 *
2112 * \apiusage{master_idle,blocking}
2113 *
2114 * \retval 0 Success.
2115 * \retval <0 Error code.
2116 */
2117 EC_PUBLIC_API int ecrt_slave_config_eoe_hostname(
2118     ec_slave_config_t *sc, /**< Slave configuration. */
2119     const char *name /**< Zero-terminated host name. */
2120 );
2121
2122 /** Sets the application-layer state transition timeout in ms.
2123 *
2124 * Change the maximum allowed time for a slave to make an application-layer
2125 * state transition for the given state transition (for example from PREOP to
2126 * SAFEOP). The default values are defined in ETG.2000.
2127 *
2128 * A timeout value of zero ms will restore the default value.
2129 *
2130 * This method has to be called in non-realtime context before
2131 * ecrt_master_activate().
2132 *
2133 * \apiusage{master_idle,blocking}
2134 *
2135 * \retval 0 Success.
2136 * \retval <0 Error code.
2137 */
2138 EC_PUBLIC_API int ecrt_slave_config_state_timeout(
2139     ec_slave_config_t *sc, /**< Slave configuration. */
2140     ec_al_state_t from_state, /**< Initial state. */
2141     ec_al_state_t to_state, /**< Target state. */
2142     unsigned int timeout_ms /**< Timeout in [ms]. */
2143 );
2144
2145 /*****
2146 * Domain methods
2147 *****/
2148
2149 /** Registers a bunch of PDO entries for a domain.

```



```

2150  *
2151  * This method has to be called in non-realtime context before
2152  * ecrt_master_activate().
2153  *
2154  * \see ecrt_slave_config_reg_pdo_entry()
2155  *
2156  * \attention The registration array has to be terminated with an empty
2157  *             structure, or one with the \a index field set to zero!
2158  *
2159  * \apiusage{master_idle,blocking}
2160  *
2161  * \return 0 on success, else non-zero.
2162  */
2163 EC_PUBLIC_API int ecrt_domain_reg_pdo_entry_list(
2164     ec_domain_t *domain, /**< Domain. */
2165     const ec_pdo_entry_reg_t *pdo_entry_regs /**< Array of PDO
2166                                             registrations. */
2167     );
2168
2169 /** Returns the current size of the domain's process data.
2170  *
2171  * The domain size is calculated after master activation.
2172  *
2173  * \apiusage{master_op,rt_safe}
2174  *
2175  * \return Size of the process data image, or a negative error code.
2176  */
2177 EC_PUBLIC_API size_t ecrt_domain_size(
2178     const ec_domain_t *domain /**< Domain. */
2179     );
2180
2181 #ifdef __KERNEL__
2182
2183 /** Provide external memory to store the domain's process data.
2184  *
2185  * Call this after all PDO entries have been registered and before activating
2186  * the master.
2187  *
2188  * The size of the allocated memory must be at least ecrt_domain_size(), after
2189  * all PDO entries have been registered.
2190  *
2191  * This method has to be called in non-realtime context before
2192  * ecrt_master_activate().
2193  *
2194  * \apiusage{master_idle,blocking}
2195  */
2196 void ecrt_domain_external_memory(
2197     ec_domain_t *domain, /**< Domain. */
2198     uint8_t *memory /**< Address of the memory to store the process
2199                      data in. */
2200     );
2201
2202 #endif /* __KERNEL__ */
2203
2204 /** Returns the domain's process data.
2205  *
2206  * - In kernel context: If external memory was provided with
2207  *   ecrt_domain_external_memory(), the returned pointer will contain the
2208  *   address of that memory. Otherwise it will point to the internally allocated
2209  *   memory. In the latter case, this method may not be called before
2210  *   ecrt_master_activate().
2211  *
2212  * - In userspace context: This method has to be called after
2213  *   ecrt_master_activate() to get the mapped domain process data memory.
2214  *
2215  * \apiusage{master_op,rt_safe}

```

```

2216 *
2217 * \return Pointer to the process data memory.
2218 */
2219 EC_PUBLIC_API uint8_t *ecrt_domain_data(
2220     const ec_domain_t *domain /**< Domain. */
2221     );
2222
2223 /** Determines the states of the domain's datagrams.
2224 *
2225 * Evaluates the working counters of the received datagrams and outputs
2226 * statistics, if necessary. This must be called after ecrt_master_receive()
2227 * is expected to receive the domain datagrams in order to make
2228 * ecrt_domain_state() return the result of the last process data exchange.
2229 *
2230 * \apiusage{master_op,rt_safe}
2231 *
2232 * \return 0 on success, otherwise negative error code.
2233 */
2234 EC_PUBLIC_API int ecrt_domain_process(
2235     ec_domain_t *domain /**< Domain. */
2236     );
2237
2238 /** (Re-)queues all domain datagrams in the master's datagram queue.
2239 *
2240 * Call this function to mark the domain's datagrams for exchanging at the
2241 * next call of ecrt_master_send().
2242 *
2243 * \apiusage{master_op,rt_safe}
2244 *
2245 * \return 0 on success, otherwise negative error code.
2246 */
2247 EC_PUBLIC_API int ecrt_domain_queue(
2248     ec_domain_t *domain /**< Domain. */
2249     );
2250
2251 /** Reads the state of a domain.
2252 *
2253 * Stores the domain state in the given \a state structure.
2254 *
2255 * Using this method, the process data exchange can be monitored in realtime.
2256 *
2257 * \apiusage{master_op,rt_safe}
2258 *
2259 * \return 0 on success, otherwise negative error code.
2260 */
2261 EC_PUBLIC_API int ecrt_domain_state(
2262     const ec_domain_t *domain, /**< Domain. */
2263     ec_domain_state_t *state /**< Pointer to a state object to store the
2264     information. */
2265     );
2266
2267 /*****
2268 * SDO request methods.
2269 *****/
2270
2271 /** Set the SDO index and subindex.
2272 *
2273 * \attention If the SDO index and/or subindex is changed while
2274 * ecrt_sdo_request_state() returns EC_REQUEST_BUSY, this may lead to
2275 * unexpected results.
2276 *
2277 * This method is meant to be called in realtime context (after master
2278 * activation). To initialize the SDO request, the index and subindex can be
2279 * set via ecrt_slave_config_create_sdo_request().
2280 *
2281 * \apiusage{master_op,rt_safe}

```

```

2282  *
2283  * \return 0 on success, otherwise negative error code.
2284  */
2285  EC_PUBLIC_API int ecrt_sdo_request_index(
2286      ec_sdo_request_t *req, /**< SDO request. */
2287      uint16_t index, /**< SDO index. */
2288      uint8_t subindex /**< SDO subindex. */
2289      );
2290
2291  /** Set the timeout for an SDO request.
2292  *
2293  * If the request cannot be processed in the specified time, it will be marked
2294  * as failed.
2295  *
2296  * The timeout is permanently stored in the request object and is valid until
2297  * the next call of this method.
2298  *
2299  * The timeout should be defined in non-realtime context, but can also be
2300  * changed afterwards.
2301  *
2302  * \apiusage{master_any,rt_safe}
2303  *
2304  * \return 0 on success, otherwise negative error code.
2305  */
2306  EC_PUBLIC_API int ecrt_sdo_request_timeout(
2307      ec_sdo_request_t *req, /**< SDO request. */
2308      uint32_t timeout /**< Timeout in milliseconds. Zero means no
2309                      timeout. */
2310      );
2311
2312  /** Access to the SDO request's data.
2313  *
2314  * This function returns a pointer to the request's internal SDO data memory.
2315  *
2316  * - After a read operation was successful, integer data can be evaluated
2317  *   using the EC_READ_*() macros as usual. Example:
2318  *   \code
2319  *   uint16_t value = EC_READ_U16(ecrt_sdo_request_data(sdo));
2320  *   \endcode
2321  * - If a write operation shall be triggered, the data have to be written to
2322  *   the internal memory. Use the EC_WRITE_*() macros, if you are writing
2323  *   integer data. Be sure, that the data fit into the memory. The memory size
2324  *   is a parameter of ecrt_slave_config_create_sdo_request().
2325  *   \code
2326  *   EC_WRITE_U16(ecrt_sdo_request_data(sdo), 0xFFFF);
2327  *   \endcode
2328  *
2329  * \attention The return value can be invalid during a read operation, because
2330  * the internal SDO data memory could be re-allocated if the read SDO data do
2331  * not fit inside.
2332  *
2333  * This method is meant to be called in realtime context (after master
2334  * activation), but can also be used to initialize data before.
2335  *
2336  * \apiusage{master_any,rt_safe}
2337  *
2338  * \return Pointer to the internal SDO data memory.
2339  *
2340  */
2341  EC_PUBLIC_API uint8_t *ecrt_sdo_request_data(
2342      const ec_sdo_request_t *req /**< SDO request. */
2343      );
2344
2345  /** Returns the current SDO data size.
2346  *
2347  * When the SDO request is created, the data size is set to the size of the

```

```

2348 * reserved memory. After a read operation the size is set to the size of the
2349 * read data. The size is not modified in any other situation.
2350 *
2351 * This method is meant to be called in realtime context (after master
2352 * activation).
2353 *
2354 * \apiusage{master_any,rt_safe}
2355 *
2356 * \return SDO data size in bytes.
2357 *
2358 */
2359 EC_PUBLIC_API size_t ecrt_sdo_request_data_size(
2360     const ec_sdo_request_t *req /**< SDO request. */
2361 );
2362
2363 /** Get the current state of the SDO request.
2364 *
2365 * The user-space implementation fetches incoming data and stores the received
2366 * data size in the request object, so the request is not const.
2367 *
2368 * This method is meant to be called in realtime context (after master
2369 * activation).
2370 *
2371 * \apiusage{master_op,rt_safe}
2372 *
2373 * \return Request state.
2374 *
2375 */
2376 EC_PUBLIC_API ec_request_state_t ecrt_sdo_request_state(
2377 #ifdef __KERNEL__
2378     const
2379 #endif
2380     ec_sdo_request_t *req /**< SDO request. */
2381 );
2382
2383 /** Schedule an SDO write operation.
2384 *
2385 * \attention This method may not be called while ecrt_sdo_request_state()
2386 * returns EC_REQUEST_BUSY.
2387 *
2388 * This method is meant to be called in realtime context (after master
2389 * activation).
2390 *
2391 * \apiusage{master_op,rt_safe}
2392 *
2393 * \return 0 on success, otherwise negative error code.
2394 * \retval -EINVAL Invalid input data, e.g. data size == 0.
2395 * \retval -ENOBUFFS Reserved memory in ecrt_slave_config_create_sdo_request()
2396 *         too small.
2397 */
2398 EC_PUBLIC_API int ecrt_sdo_request_write(
2399     ec_sdo_request_t *req /**< SDO request. */
2400 );
2401
2402 /** Schedule an SDO read operation.
2403 *
2404 * \attention This method may not be called while ecrt_sdo_request_state()
2405 * returns EC_REQUEST_BUSY.
2406 *
2407 * \attention After calling this function, the return value of
2408 * ecrt_sdo_request_data() must be considered as invalid while
2409 * ecrt_sdo_request_state() returns EC_REQUEST_BUSY.
2410 *
2411 * This method is meant to be called in realtime context (after master
2412 * activation).
2413 *

```

```

2414 * \apiusage{master_op,rt_safe}
2415 *
2416 * \return 0 on success, otherwise negative error code.
2417 */
2418 EC_PUBLIC_API int ecrt_sdo_request_read(
2419     ec_sdo_request_t *req /**< SDO request. */
2420     );
2421
2422 /*****
2423  * SoE request methods.
2424  *****/
2425
2426 /** Set the request's drive and Sercos ID numbers.
2427  *
2428  * \attention If the drive number and/or IDN is changed while
2429  * ecrt_soe_request_state() returns EC_REQUEST_BUSY, this may lead to
2430  * unexpected results.
2431  *
2432  * This method is meant to be called in realtime context (after master
2433  * activation). To initialize the SoE request, the drive_no and IDN can be
2434  * set via ecrt_slave_config_create_soe_request().
2435  *
2436  * \apiusage{master_op,rt_safe}
2437  *
2438  * \return 0 on success, otherwise negative error code.
2439  */
2440 EC_PUBLIC_API int ecrt_soe_request_idn(
2441     ec_soe_request_t *req, /**< IDN request. */
2442     uint8_t drive_no, /**< SDO index. */
2443     uint16_t idn /**< SoE IDN. */
2444     );
2445
2446 /** Set the timeout for an SoE request.
2447  *
2448  * If the request cannot be processed in the specified time, it will be marked
2449  * as failed.
2450  *
2451  * The timeout is permanently stored in the request object and is valid until
2452  * the next call of this method.
2453  *
2454  * The timeout should be defined in non-realtime context, but can also be
2455  * changed afterwards.
2456  *
2457  * \apiusage{master_any,rt_safe}
2458  *
2459  * \return 0 on success, otherwise negative error code.
2460  */
2461 EC_PUBLIC_API int ecrt_soe_request_timeout(
2462     ec_soe_request_t *req, /**< SoE request. */
2463     uint32_t timeout /**< Timeout in milliseconds. Zero means no
2464     timeout. */
2465     );
2466
2467 /** Access to the SoE request's data.
2468  *
2469  * This function returns a pointer to the request's internal IDN data memory.
2470  *
2471  * - After a read operation was successful, integer data can be evaluated
2472  *   using the EC_READ_*() macros as usual. Example:
2473  *   \code
2474  *   uint16_t value = EC_READ_U16(ecrt_soe_request_data(idn_req));
2475  *   \endcode
2476  * - If a write operation shall be triggered, the data have to be written to
2477  *   the internal memory. Use the EC_WRITE_*() macros, if you are writing
2478  *   integer data. Be sure, that the data fit into the memory. The memory size
2479  *   is a parameter of ecrt_slave_config_create_soe_request().

```

```

2480 *   \code
2481 *   EC_WRITE_U16(ecrt_soe_request_data(idn_req), 0xFFFF);
2482 *   \endcode
2483 *
2484 * \attention The return value can be invalidated during a read operation,
2485 * because the internal IDN data memory could be re-allocated if the read IDN
2486 * data do not fit inside.
2487 *
2488 * This method is meant to be called in realtime context (after master
2489 * activation), but can also be used to initialize data before.
2490 *
2491 * \apiusage{master_any,rt_safe}
2492 *
2493 * \return Pointer to the internal IDN data memory.
2494 *
2495 */
2496 EC_PUBLIC_API uint8_t *ecrt_soe_request_data(
2497     const ec_soe_request_t *req /**< SoE request. */
2498 );
2499
2500 /** Returns the current IDN data size.
2501 *
2502 * When the SoE request is created, the data size is set to the size of the
2503 * reserved memory. After a read operation the size is set to the size of the
2504 * read data. The size is not modified in any other situation.
2505 *
2506 * \apiusage{master_any,rt_safe}
2507 *
2508 * \return IDN data size in bytes.
2509 */
2510 EC_PUBLIC_API size_t ecrt_soe_request_data_size(
2511     const ec_soe_request_t *req /**< SoE request. */
2512 );
2513
2514 /** Get the current state of the SoE request.
2515 *
2516 * \return Request state.
2517 *
2518 * This method is meant to be called in realtime context (after master
2519 * activation).
2520 *
2521 * In the user-space implementation, the method fetches the size of the
2522 * incoming data, so the request object is not const.
2523 *
2524 * \apiusage{master_op,rt_safe}
2525 */
2526 EC_PUBLIC_API ec_request_state_t ecrt_soe_request_state(
2527 #ifdef __KERNEL__
2528     const
2529 #endif
2530     ec_soe_request_t *req /**< SoE request. */
2531 );
2532
2533 /** Schedule an SoE IDN write operation.
2534 *
2535 * \attention This method may not be called while ecrt_soe_request_state()
2536 * returns EC_REQUEST_BUSY.
2537 *
2538 * This method is meant to be called in realtime context (after master
2539 * activation).
2540 *
2541 * \apiusage{master_op,rt_safe}
2542 *
2543 * \return 0 on success, otherwise negative error code.
2544 * \retval -EINVAL Invalid input data, e.g. data size == 0.
2545 * \retval -ENOBUFS Reserved memory in ecrt_slave_config_create_soe_request()

```

```

2546 *           too small.
2547 */
2548 EC_PUBLIC_API int ecrt_soe_request_write(
2549     ec_soe_request_t *req /**< SoE request. */
2550 );
2551
2552 /** Schedule an SoE IDN read operation.
2553 *
2554 * \attention This method may not be called while ecrt_soe_request_state()
2555 * returns EC_REQUEST_BUSY.
2556 *
2557 * \attention After calling this function, the return value of
2558 * ecrt_soe_request_data() must be considered as invalid while
2559 * ecrt_soe_request_state() returns EC_REQUEST_BUSY.
2560 *
2561 * This method is meant to be called in realtime context (after master
2562 * activation).
2563 *
2564 * \apiusage{master_op,rt_safe}
2565 *
2566 * \return 0 on success, otherwise negative error code.
2567 */
2568 EC_PUBLIC_API int ecrt_soe_request_read(
2569     ec_soe_request_t *req /**< SoE request. */
2570 );
2571
2572 /*****
2573 * VoE handler methods.
2574 *****/
2575
2576 /** Sets the VoE header for future send operations.
2577 *
2578 * A VoE message shall contain a 4-byte vendor ID, followed by a 2-byte vendor
2579 * type at as header. These numbers can be set with this function. The values
2580 * are valid and will be used for future send operations until the next call
2581 * of this method.
2582 *
2583 * This method is meant to be called in non-realtime context (before master
2584 * activation) to initialize the header data, but it is also safe to
2585 * change the header later on in realtime context.
2586 *
2587 * \apiusage{master_any,rt_safe}
2588 *
2589 * \return 0 on success, otherwise negative error code.
2590 */
2591 EC_PUBLIC_API int ecrt_voe_handler_send_header(
2592     ec_voe_handler_t *voe, /**< VoE handler. */
2593     uint32_t vendor_id, /**< Vendor ID. */
2594     uint16_t vendor_type /**< Vendor-specific type. */
2595 );
2596
2597 /** Reads the header data of a received VoE message.
2598 *
2599 * This method can be used to get the received VoE header information after a
2600 * read operation has succeeded.
2601 *
2602 * The header information is stored at the memory given by the pointer
2603 * parameters.
2604 *
2605 * This method is meant to be called in realtime context (after master
2606 * activation).
2607 *
2608 * \apiusage{master_op,rt_safe}
2609 *
2610 * \return 0 on success, otherwise negative error code.
2611 */

```

```
2612 EC_PUBLIC_API int ecrt_voe_handler_received_header(  
2613     const ec_voe_handler_t *voe, /**< VoE handler. */  
2614     uint32_t *vendor_id, /**< Vendor ID. */  
2615     uint16_t *vendor_type /**< Vendor-specific type. */  
2616     );  
2617  
2618 /** Access to the VoE handler's data.  
2619  *  
2620  * This function returns a pointer to the VoE handler's internal memory, that  
2621  * points to the actual VoE data right after the VoE header (see  
2622  * ecrt_voe_handler_send_header()).  
2623  *  
2624  * - After a read operation was successful, the memory contains the received  
2625  * data. The size of the received data can be determined via  
2626  * ecrt_voe_handler_data_size().  
2627  * - Before a write operation is triggered, the data have to be written to the  
2628  * internal memory. Be sure, that the data fit into the memory. The reserved  
2629  * memory size is a parameter of ecrt_slave_config_create_voe_handler().  
2630  *  
2631  * \attention The returned pointer is not necessarily persistent: After a read  
2632  * operation, the internal memory may have been reallocated. This can be  
2633  * avoided by reserving enough memory via the \a size parameter of  
2634  * ecrt_slave_config_create_voe_handler().  
2635  *  
2636  * \apiusage{master_any,rt_safe}  
2637  *  
2638  * \return Pointer to the internal memory.  
2639  */  
2640 EC_PUBLIC_API uint8_t *ecrt_voe_handler_data(  
2641     const ec_voe_handler_t *voe /**< VoE handler. */  
2642     );  
2643  
2644 /** Returns the current data size.  
2645  *  
2646  * The data size is the size of the VoE data without the header (see  
2647  * ecrt_voe_handler_send_header()).  
2648  *  
2649  * When the VoE handler is created, the data size is set to the size of the  
2650  * reserved memory. At a write operation, the data size is set to the number  
2651  * of bytes to write. After a read operation the size is set to the size of  
2652  * the read data. The size is not modified in any other situation.  
2653  *  
2654  * \apiusage{master_any,rt_safe}  
2655  *  
2656  * \return Data size in bytes.  
2657  */  
2658 EC_PUBLIC_API size_t ecrt_voe_handler_data_size(  
2659     const ec_voe_handler_t *voe /**< VoE handler. */  
2660     );  
2661  
2662 /** Start a VoE write operation.  
2663  *  
2664  * After this function has been called, the ecrt_voe_handler_execute() method  
2665  * must be called in every realtime cycle as long as it returns  
2666  * EC_REQUEST_BUSY. No other operation may be started while the handler is  
2667  * busy.  
2668  *  
2669  * This method is meant to be called in realtime context (after master  
2670  * activation).  
2671  *  
2672  * \apiusage{master_op,rt_safe}  
2673  *  
2674  * \return 0 on success, otherwise negative error code.  
2675  * \retval -ENOBUFS Reserved memory in ecrt_slave_config_create_voe_handler  
2676  *         too small.  
2677  */
```



```

2678 EC_PUBLIC_API int ecrt_voe_handler_write(
2679     ec_voe_handler_t *voe, /**< VoE handler. */
2680     size_t size /**< Number of bytes to write (without the VoE header). */
2681     );
2682
2683 /** Start a VoE read operation.
2684  *
2685  * After this function has been called, the ecrt_voe_handler_execute() method
2686  * must be called in every realtime cycle as long as it returns
2687  * EC_REQUEST_BUSY. No other operation may be started while the handler is
2688  * busy.
2689  *
2690  * The state machine queries the slave's send mailbox for new data to be send
2691  * to the master. If no data appear within the EC_VOE_RESPONSE_TIMEOUT
2692  * (defined in master/voe_handler.c), the operation fails.
2693  *
2694  * On success, the size of the read data can be determined via
2695  * ecrt_voe_handler_data_size(), while the VoE header of the received data
2696  * can be retrieved with ecrt_voe_handler_received_header().
2697  *
2698  * This method is meant to be called in realtime context (after master
2699  * activation).
2700  *
2701  * \apiusage{master_op,rt_safe}
2702  *
2703  * \return 0 on success, otherwise negative error code.
2704  */
2705 EC_PUBLIC_API int ecrt_voe_handler_read(
2706     ec_voe_handler_t *voe /**< VoE handler. */
2707     );
2708
2709 /** Start a VoE read operation without querying the sync manager status.
2710  *
2711  * After this function has been called, the ecrt_voe_handler_execute() method
2712  * must be called in every realtime cycle as long as it returns
2713  * EC_REQUEST_BUSY. No other operation may be started while the handler is
2714  * busy.
2715  *
2716  * The state machine queries the slave by sending an empty mailbox. The slave
2717  * fills its data to the master in this mailbox. If no data appear within the
2718  * EC_VOE_RESPONSE_TIMEOUT (defined in master/voe_handler.c), the operation
2719  * fails.
2720  *
2721  * On success, the size of the read data can be determined via
2722  * ecrt_voe_handler_data_size(), while the VoE header of the received data
2723  * can be retrieved with ecrt_voe_handler_received_header().
2724  *
2725  * This method is meant to be called in realtime context (after master
2726  * activation).
2727  *
2728  * \apiusage{master_op,rt_safe}
2729  *
2730  * \return 0 on success, otherwise negative error code.
2731  */
2732 EC_PUBLIC_API int ecrt_voe_handler_read_nosync(
2733     ec_voe_handler_t *voe /**< VoE handler. */
2734     );
2735
2736 /** Execute the handler.
2737  *
2738  * This method executes the VoE handler. It has to be called in every realtime
2739  * cycle as long as it returns EC_REQUEST_BUSY.
2740  *
2741  * \return Handler state.
2742  *
2743  * This method is meant to be called in realtime context (after master

```

```
2744 * activation).
2745 *
2746 * \apiusage{master_op,rt_safe}
2747 *
2748 */
2749 EC_PUBLIC_API ec_request_state_t ecrt_voe_handler_execute(
2750     ec_voe_handler_t *voe /**< VoE handler. */
2751     );
2752
2753 /*****
2754 * Register request methods.
2755 *****/
2756
2757 /** Access to the register request's data.
2758 *
2759 * This function returns a pointer to the request's internal memory.
2760 *
2761 * - After a read operation was successful, integer data can be evaluated
2762 *   using the EC_READ_*() macros as usual. Example:
2763 *   \code
2764 *   uint16_t value = EC_READ_U16(ecrt_reg_request_data(reg_request));
2765 *   \endcode
2766 * - If a write operation shall be triggered, the data have to be written to
2767 *   the internal memory. Use the EC_WRITE_*() macros, if you are writing
2768 *   integer data. Be sure, that the data fit into the memory. The memory size
2769 *   is a parameter of ecrt_slave_config_create_reg_request().
2770 *   \code
2771 *   EC_WRITE_U16(ecrt_reg_request_data(reg_request), 0xFFFF);
2772 *   \endcode
2773 *
2774 * This method is meant to be called in realtime context (after master
2775 * activation), but can also be used to initialize data before.
2776 *
2777 * \apiusage{master_any,rt_safe}
2778 *
2779 * \return Pointer to the internal memory.
2780 *
2781 */
2782 EC_PUBLIC_API uint8_t *ecrt_reg_request_data(
2783     const ec_reg_request_t *req /**< Register request. */
2784     );
2785
2786 /** Get the current state of the register request.
2787 *
2788 * This method is meant to be called in realtime context (after master
2789 * activation).
2790 *
2791 * \apiusage{master_op,rt_safe}
2792 *
2793 * \return Request state.
2794 *
2795 */
2796 EC_PUBLIC_API ec_request_state_t ecrt_reg_request_state(
2797     const ec_reg_request_t *req /**< Register request. */
2798     );
2799
2800 /** Schedule an register write operation.
2801 *
2802 * \attention This method may not be called while ecrt_reg_request_state()
2803 * returns EC_REQUEST_BUSY.
2804 *
2805 * \attention The \a size parameter is truncated to the size given at request
2806 * creation.
2807 *
2808 * This method is meant to be called in realtime context (after master
2809 * activation).
```

```

2810  *
2811  * \apiusage{master_op,rt_safe}
2812  *
2813  * \return 0 on success, otherwise negative error code.
2814  * \retval -ENOBUFS Reserved memory in ecrt_slave_config_create_reg_request
2815  *         too small.
2816  */
2817 EC_PUBLIC_API int ecrt_reg_request_write(
2818     ec_reg_request_t *req, /**< Register request. */
2819     uint16_t address, /**< Register address. */
2820     size_t size /**< Size to write. */
2821 );
2822
2823 /** Schedule a register read operation.
2824  *
2825  * \attention This method may not be called while ecrt_reg_request_state()
2826  * returns EC_REQUEST_BUSY.
2827  *
2828  * \attention The \a size parameter is truncated to the size given at request
2829  * creation.
2830  *
2831  * This method is meant to be called in realtime context (after master
2832  * activation).
2833  *
2834  * \apiusage{master_op,rt_safe}
2835  *
2836  * \return 0 on success, otherwise negative error code.
2837  * \retval -ENOBUFS Reserved memory in ecrt_slave_config_create_reg_request
2838  *         too small.
2839  */
2840 EC_PUBLIC_API int ecrt_reg_request_read(
2841     ec_reg_request_t *req, /**< Register request. */
2842     uint16_t address, /**< Register address. */
2843     size_t size /**< Size to write. */
2844 );
2845
2846 /*****
2847  * Bitwise read/write macros
2848  *****/
2849
2850 /** Read a certain bit of an EtherCAT data byte.
2851  *
2852  * \param DATA EtherCAT data pointer
2853  * \param POS bit position
2854  */
2855 #define EC_READ_BIT(DATA, POS) (((uint8_t *) (DATA)) >> (POS)) & 0x01
2856
2857 /** Write a certain bit of an EtherCAT data byte.
2858  *
2859  * \param DATA EtherCAT data pointer
2860  * \param POS bit position
2861  * \param VAL new bit value
2862  */
2863 #define EC_WRITE_BIT(DATA, POS, VAL) \
2864     do { \
2865         if (VAL) *((uint8_t *) (DATA)) |= (1 << (POS)); \
2866         else    *((uint8_t *) (DATA)) &= ~(1 << (POS)); \
2867     } while (0)
2868
2869 /*****
2870  * Byte-swapping functions for user space
2871  *****/
2872
2873 #ifndef __KERNEL__
2874
2875 #if __BYTE_ORDER == __LITTLE_ENDIAN

```

```
2876
2877 #define le16_to_cpu(x) x
2878 #define le32_to_cpu(x) x
2879 #define le64_to_cpu(x) x
2880
2881 #define cpu_to_le16(x) x
2882 #define cpu_to_le32(x) x
2883 #define cpu_to_le64(x) x
2884
2885 #elif __BYTE_ORDER == __BIG_ENDIAN
2886
2887 #define swap16(x) \
2888     ((uint16_t)( \
2889         ((uint16_t)(x) & 0x00ffU) << 8) | \
2890         ((uint16_t)(x) & 0xff00U) >> 8) )
2891 #define swap32(x) \
2892     ((uint32_t)( \
2893         ((uint32_t)(x) & 0x000000ffUL) << 24) | \
2894         ((uint32_t)(x) & 0x0000ff00UL) << 8) | \
2895         ((uint32_t)(x) & 0x00ff0000UL) >> 8) | \
2896         ((uint32_t)(x) & 0xff000000UL) >> 24) )
2897 #define swap64(x) \
2898     ((uint64_t)( \
2899         ((uint64_t)(x) & 0x00000000000000ffULL) << 56) | \
2900         ((uint64_t)(x) & 0x000000000000ff00ULL) << 40) | \
2901         ((uint64_t)(x) & 0x0000000000ff0000ULL) << 24) | \
2902         ((uint64_t)(x) & 0x00000000ff000000ULL) << 8) | \
2903         ((uint64_t)(x) & 0x000000ff00000000ULL) >> 8) | \
2904         ((uint64_t)(x) & 0x0000ff0000000000ULL) >> 24) | \
2905         ((uint64_t)(x) & 0x00ff000000000000ULL) >> 40) | \
2906         ((uint64_t)(x) & 0xff00000000000000ULL) >> 56) )
2907
2908 #define le16_to_cpu(x) swap16(x)
2909 #define le32_to_cpu(x) swap32(x)
2910 #define le64_to_cpu(x) swap64(x)
2911
2912 #define cpu_to_le16(x) swap16(x)
2913 #define cpu_to_le32(x) swap32(x)
2914 #define cpu_to_le64(x) swap64(x)
2915
2916 #endif
2917
2918 #define le16_to_cpup(x) le16_to_cpu(*((uint16_t *) (x)))
2919 #define le32_to_cpup(x) le32_to_cpu(*((uint32_t *) (x)))
2920 #define le64_to_cpup(x) le64_to_cpu(*((uint64_t *) (x)))
2921
2922 #endif /* ifndef __KERNEL__ */
2923
2924 /*****
2925  * Read macros
2926  *****/
2927
2928 /** Read an 8-bit unsigned value from EtherCAT data.
2929  *
2930  * \return EtherCAT data value
2931  */
2932 #define EC_READ_U8(DATA) \
2933     ((uint8_t) *((uint8_t *) (DATA)))
2934
2935 /** Read an 8-bit signed value from EtherCAT data.
2936  *
2937  * \param DATA EtherCAT data pointer
2938  * \return EtherCAT data value
2939  */
2940 #define EC_READ_S8(DATA) \
2941     ((int8_t) *((uint8_t *) (DATA)))
```

```

2942
2943 /** Read a 16-bit unsigned value from EtherCAT data.
2944  *
2945  * \param DATA EtherCAT data pointer
2946  * \return EtherCAT data value
2947  */
2948 #define EC_READ_U16(DATA) \
2949     ((uint16_t) le16_to_cpup((void *) (DATA)))
2950
2951 /** Read a 16-bit signed value from EtherCAT data.
2952  *
2953  * \param DATA EtherCAT data pointer
2954  * \return EtherCAT data value
2955  */
2956 #define EC_READ_S16(DATA) \
2957     ((int16_t) le16_to_cpup((void *) (DATA)))
2958
2959 /** Read a 32-bit unsigned value from EtherCAT data.
2960  *
2961  * \param DATA EtherCAT data pointer
2962  * \return EtherCAT data value
2963  */
2964 #define EC_READ_U32(DATA) \
2965     ((uint32_t) le32_to_cpup((void *) (DATA)))
2966
2967 /** Read a 32-bit signed value from EtherCAT data.
2968  *
2969  * \param DATA EtherCAT data pointer
2970  * \return EtherCAT data value
2971  */
2972 #define EC_READ_S32(DATA) \
2973     ((int32_t) le32_to_cpup((void *) (DATA)))
2974
2975 /** Read a 64-bit unsigned value from EtherCAT data.
2976  *
2977  * \param DATA EtherCAT data pointer
2978  * \return EtherCAT data value
2979  */
2980 #define EC_READ_U64(DATA) \
2981     ((uint64_t) le64_to_cpup((void *) (DATA)))
2982
2983 /** Read a 64-bit signed value from EtherCAT data.
2984  *
2985  * \param DATA EtherCAT data pointer
2986  * \return EtherCAT data value
2987  */
2988 #define EC_READ_S64(DATA) \
2989     ((int64_t) le64_to_cpup((void *) (DATA)))
2990
2991 /*****
2992  * Floating-point read functions and macros (userspace only)
2993  *****/
2994
2995 #ifndef __KERNEL__
2996
2997 /** Read a 32-bit floating-point value from EtherCAT data.
2998  *
2999  * \apiusage{master_any,rt_safe}
3000  *
3001  * \param data EtherCAT data pointer
3002  * \return EtherCAT data value
3003  */
3004 EC_PUBLIC_API float ecrt_read_real(const void *data);
3005
3006 /** Read a 32-bit floating-point value from EtherCAT data.
3007  *

```

```
3008 * \param DATA EtherCAT data pointer
3009 * \return EtherCAT data value
3010 */
3011 #define EC_READ_REAL(DATA) ecrt_read_real(DATA)
3012
3013 /** Read a 64-bit floating-point value from EtherCAT data.
3014 *
3015 * \apiusage{master_any,rt_safe}
3016 *
3017 * \param data EtherCAT data pointer
3018 * \return EtherCAT data value
3019 */
3020 EC_PUBLIC_API double ecrt_read_lreal(const void *data);
3021
3022 /** Read a 64-bit floating-point value from EtherCAT data.
3023 *
3024 * \param DATA EtherCAT data pointer
3025 * \return EtherCAT data value
3026 */
3027 #define EC_READ_LREAL(DATA) ecrt_read_lreal(DATA)
3028
3029 #endif // ifndef __KERNEL__
3030
3031 /*****
3032 * Write macros
3033 *****/
3034
3035 /** Write an 8-bit unsigned value to EtherCAT data.
3036 *
3037 * \param DATA EtherCAT data pointer
3038 * \param VAL new value
3039 */
3040 #define EC_WRITE_U8(DATA, VAL) \
3041     do { \
3042         *((uint8_t *) (DATA)) = ((uint8_t) (VAL)); \
3043     } while (0)
3044
3045 /** Write an 8-bit signed value to EtherCAT data.
3046 *
3047 * \param DATA EtherCAT data pointer
3048 * \param VAL new value
3049 */
3050 #define EC_WRITE_S8(DATA, VAL) EC_WRITE_U8(DATA, VAL)
3051
3052 /** Write a 16-bit unsigned value to EtherCAT data.
3053 *
3054 * \param DATA EtherCAT data pointer
3055 * \param VAL new value
3056 */
3057 #define EC_WRITE_U16(DATA, VAL) \
3058     do { \
3059         *((uint16_t *) (DATA)) = cpu_to_le16((uint16_t) (VAL)); \
3060     } while (0)
3061
3062 /** Write a 16-bit signed value to EtherCAT data.
3063 *
3064 * \param DATA EtherCAT data pointer
3065 * \param VAL new value
3066 */
3067 #define EC_WRITE_S16(DATA, VAL) EC_WRITE_U16(DATA, VAL)
3068
3069 /** Write a 32-bit unsigned value to EtherCAT data.
3070 *
3071 * \param DATA EtherCAT data pointer
3072 * \param VAL new value
3073 */
```

```

3074 #define EC_WRITE_U32(DATA, VAL) \
3075     do { \
3076         *((uint32_t *) (DATA)) = cpu_to_le32((uint32_t) (VAL)); \
3077     } while (0)
3078
3079 /** Write a 32-bit signed value to EtherCAT data.
3080  *
3081  * \param DATA EtherCAT data pointer
3082  * \param VAL new value
3083  */
3084 #define EC_WRITE_S32(DATA, VAL) EC_WRITE_U32(DATA, VAL)
3085
3086 /** Write a 64-bit unsigned value to EtherCAT data.
3087  *
3088  * \param DATA EtherCAT data pointer
3089  * \param VAL new value
3090  */
3091 #define EC_WRITE_U64(DATA, VAL) \
3092     do { \
3093         *((uint64_t *) (DATA)) = cpu_to_le64((uint64_t) (VAL)); \
3094     } while (0)
3095
3096 /** Write a 64-bit signed value to EtherCAT data.
3097  *
3098  * \param DATA EtherCAT data pointer
3099  * \param VAL new value
3100  */
3101 #define EC_WRITE_S64(DATA, VAL) EC_WRITE_U64(DATA, VAL)
3102
3103 /*****
3104  * Floating-point write functions and macros (userspace only)
3105  *****/
3106
3107 #ifndef __KERNEL__
3108
3109 /** Write a 32-bit floating-point value to EtherCAT data.
3110  *
3111  * \apiusage{master_any,rt_safe}
3112  *
3113  * \param data EtherCAT data pointer
3114  * \param value new value
3115  */
3116 EC_PUBLIC_API void ecrt_write_real(void *data, float value);
3117
3118 /** Write a 32-bit floating-point value to EtherCAT data.
3119  *
3120  * \param DATA EtherCAT data pointer
3121  * \param VAL new value
3122  */
3123 #define EC_WRITE_REAL(DATA, VAL) ecrt_write_real(DATA, VAL)
3124
3125 /** Write a 64-bit floating-point value to EtherCAT data.
3126  *
3127  * \apiusage{master_any,rt_safe}
3128  *
3129  * \param data EtherCAT data pointer
3130  * \param value new value
3131  */
3132 EC_PUBLIC_API void ecrt_write_lreal(void *data, double value);
3133
3134 /** Write a 64-bit floating-point value to EtherCAT data.
3135  *
3136  * \param DATA EtherCAT data pointer
3137  * \param VAL new value
3138  */
3139 #define EC_WRITE_LREAL(DATA, VAL) ecrt_write_lreal(DATA, VAL)

```

```
3140
3141 #endif // ifndef __KERNEL__
3142
3143 /*****
3144
3145 #ifdef __cplusplus
3146 }
3147 #endif
3148
3149 /*****
3150
3151 /** @} */
3152
3153 #endif
```

3.7 Userspace Application Example

There are multiple examples of how to use the application interface included in the master sources (under *examples/*). This section lists a very common application, the usage of the master from the user-space. The example code reserves an EtherCAT master, creates slave configurations and domains and goes into cyclic mode, where the `cyclic_task()` function is called repeatedly. For more general information on how to do real-time programming under Linux, please have a look at the code examples in <https://gitlab.com/etherlab.org/realtime>.

Listing 3.2: Userspace application example `example/user/main.c`

```
1 /*****
2 *
3 * Copyright (C) 2007-2009 Florian Pose, Ingenieurgemeinschaft IgH
4 *
5 * This file is part of the IgH EtherCAT Master.
6 *
7 * The IgH EtherCAT Master is free software; you can redistribute it and/or
8 * modify it under the terms of the GNU General Public License version 2, as
9 * published by the Free Software Foundation.
10 *
11 * The IgH EtherCAT Master is distributed in the hope that it will be useful,
12 * but WITHOUT ANY WARRANTY; without even the implied warranty of
13 * MERCHANTABILITY or FITNESS FOR A PARTICULAR PURPOSE. See the GNU General
14 * Public License for more details.
15 *
16 * You should have received a copy of the GNU General Public License along
17 * with the IgH EtherCAT Master; if not, write to the Free Software
18 * Foundation, Inc., 51 Franklin St, Fifth Floor, Boston, MA 02110-1301 USA
19 *
20 *****/
21
22 #include <errno.h>
23 #include <signal.h>
24 #include <stdio.h>
25 #include <string.h>
26 #include <sys/resource.h>
27 #include <sys/time.h>
28 #include <sys/types.h>
29 #include <unistd.h>
30 #include <time.h> /* clock_gettime() */
31 #include <sys/mman.h> /* mlockall() */
```



```

32 #include <sched.h> /* sched_setscheduler() */
33
34 /*****
35
36 #include "ecrt.h"
37
38 /*****
39
40 /** Task period in ns. */
41 #define PERIOD_NS    (1000000)
42
43 #define MAX_SAFE_STACK (8 * 1024) /* The maximum stack size which is
44                                     guranteed safe to access without
45                                     faulting */
46
47 /*****
48
49 /* Constants */
50 #define NSEC_PER_SEC (1000000000)
51 #define FREQUENCY (NSEC_PER_SEC / PERIOD_NS)
52
53 /*****
54
55 // EtherCAT
56 static ec_master_t *master = NULL;
57 static ec_master_state_t master_state = {};
58
59 static ec_domain_t *domain1 = NULL;
60 static ec_domain_state_t domain1_state = {};
61
62 static ec_slave_config_t *sc_ana_in = NULL;
63 static ec_slave_config_state_t sc_ana_in_state = {};
64
65 /*****
66
67 // process data
68 static uint8_t *domain1_pd = NULL;
69
70 #define BusCouplerPos    0, 0
71 #define DigOutSlavePos  0, 2
72 #define AnaInSlavePos   0, 3
73 #define AnaOutSlavePos  0, 4
74
75 #define Beckhoff_EK1100 0x00000002, 0x044c2c52
76 #define Beckhoff_EL2004 0x00000002, 0x07d43052
77 #define Beckhoff_EL2032 0x00000002, 0x07f03052
78 #define Beckhoff_EL3152 0x00000002, 0x0c503052
79 #define Beckhoff_EL3102 0x00000002, 0x0c1e3052
80 #define Beckhoff_EL4102 0x00000002, 0x10063052
81
82 // offsets for PDO entries
83 static unsigned int off_ana_in_status;
84 static unsigned int off_ana_in_value;
85 static unsigned int off_ana_out;
86 static unsigned int off_dig_out;
87
88 const static ec_pdo_entry_reg_t domain1_regs[] = {
89     {AnaInSlavePos, Beckhoff_EL3102, 0x3101, 1, &off_ana_in_status},
90     {AnaInSlavePos, Beckhoff_EL3102, 0x3101, 2, &off_ana_in_value},
91     {AnaOutSlavePos, Beckhoff_EL4102, 0x3001, 1, &off_ana_out},
92     {DigOutSlavePos, Beckhoff_EL2032, 0x3001, 1, &off_dig_out},
93     {}
94 };
95
96 static unsigned int counter = 0;
97 static unsigned int blink = 0;

```

```
98
99 /*****
100
101 // Analog in -----
102
103 static const ec_pdo_entry_info_t el3102_pdo_entries[] = {
104     {0x3101, 1, 8}, // channel 1 status
105     {0x3101, 2, 16}, // channel 1 value
106     {0x3102, 1, 8}, // channel 2 status
107     {0x3102, 2, 16}, // channel 2 value
108     {0x6401, 1, 16}, // channel 1 value (alt.)
109     {0x6401, 2, 16} // channel 2 value (alt.)
110 };
111
112 static const ec_pdo_info_t el3102_pdos[] = {
113     {0x1A00, 2, el3102_pdo_entries},
114     {0x1A01, 2, el3102_pdo_entries + 2}
115 };
116
117 static const ec_sync_info_t el3102_syncs[] = {
118     {2, EC_DIR_OUTPUT},
119     {3, EC_DIR_INPUT, 2, el3102_pdos},
120     {0xff}
121 };
122
123 // Analog out -----
124
125 static const ec_pdo_entry_info_t el4102_pdo_entries[] = {
126     {0x3001, 1, 16}, // channel 1 value
127     {0x3002, 1, 16}, // channel 2 value
128 };
129
130 static const ec_pdo_info_t el4102_pdos[] = {
131     {0x1600, 1, el4102_pdo_entries},
132     {0x1601, 1, el4102_pdo_entries + 1}
133 };
134
135 static const ec_sync_info_t el4102_syncs[] = {
136     {2, EC_DIR_OUTPUT, 2, el4102_pdos},
137     {3, EC_DIR_INPUT},
138     {0xff}
139 };
140
141 // Digital out -----
142
143 static const ec_pdo_entry_info_t el2004_channels[] = {
144     {0x3001, 1, 1}, // Value 1
145     {0x3001, 2, 1}, // Value 2
146     {0x3001, 3, 1}, // Value 3
147     {0x3001, 4, 1} // Value 4
148 };
149
150 static const ec_pdo_info_t el2004_pdos[] = {
151     {0x1600, 1, &el2004_channels[0]},
152     {0x1601, 1, &el2004_channels[1]},
153     {0x1602, 1, &el2004_channels[2]},
154     {0x1603, 1, &el2004_channels[3]}
155 };
156
157 static const ec_sync_info_t el2004_syncs[] = {
158     {0, EC_DIR_OUTPUT, 4, el2004_pdos},
159     {1, EC_DIR_INPUT},
160     {0xff}
161 };
162
163 /*****/
```

```

164
165 void check_domain1_state(void)
166 {
167     ec_domain_state_t ds;
168
169     ecrt_domain_state(domain1, &ds);
170
171     if (ds.working_counter != domain1_state.working_counter) {
172         printf("Domain1: WC %u.\n", ds.working_counter);
173     }
174     if (ds.wc_state != domain1_state.wc_state) {
175         printf("Domain1: State %u.\n", ds.wc_state);
176     }
177
178     domain1_state = ds;
179 }
180
181 /*****/
182
183 void check_master_state(void)
184 {
185     ec_master_state_t ms;
186
187     ecrt_master_state(master, &ms);
188
189     if (ms.slaves_responding != master_state.slaves_responding) {
190         printf("%u slave(s).\n", ms.slaves_responding);
191     }
192     if (ms.al_states != master_state.al_states) {
193         printf("AL states: 0x%02X.\n", ms.al_states);
194     }
195     if (ms.link_up != master_state.link_up) {
196         printf("Link is %s.\n", ms.link_up ? "up" : "down");
197     }
198
199     master_state = ms;
200 }
201
202 /*****/
203
204 void check_slave_config_states(void)
205 {
206     ec_slave_config_state_t s;
207
208     ecrt_slave_config_state(sc_ana_in, &s);
209
210     if (s.al_state != sc_ana_in_state.al_state) {
211         printf("AnaIn: State 0x%02X.\n", s.al_state);
212     }
213     if (s.online != sc_ana_in_state.online) {
214         printf("AnaIn: %s.\n", s.online ? "online" : "offline");
215     }
216     if (s.operational != sc_ana_in_state.operational) {
217         printf("AnaIn: %soperational.\n", s.operational ? "" : "Not");
218     }
219
220     sc_ana_in_state = s;
221 }
222
223 /*****/
224
225 void cyclic_task()
226 {
227     // receive process data
228     ecrt_master_receive(master);
229     ecrt_domain_process(domain1);

```

```
230
231 // check process data state
232 check_domain1_state();
233
234 if (counter) {
235     counter--;
236 } else { // do this at 1 Hz
237     counter = FREQUENCY;
238
239     // calculate new process data
240     blink = !blink;
241
242     // check for master state (optional)
243     check_master_state();
244
245     // check for slave configuration state(s) (optional)
246     check_slave_config_states();
247 }
248
249 #if 0
250 // read process data
251 printf("AnaIn: state %u value %u\n",
252        EC_READ_U8(domain1_pd + off_ana_in_status),
253        EC_READ_U16(domain1_pd + off_ana_in_value));
254 #endif
255
256 #if 1
257 // write process data
258 EC_WRITE_U8(domain1_pd + off_dig_out, blink ? 0x06 : 0x09);
259 #endif
260
261 // send process data
262 ecrt_domain_queue(domain1);
263 ecrt_master_send(master);
264 }
265
266 /*****
267
268 void stack_pdefault(void)
269 {
270     unsigned char dummy[MAX_SAFE_STACK];
271
272     memset(dummy, 0, MAX_SAFE_STACK);
273 }
274
275 /*****
276
277 int main(int argc, char **argv)
278 {
279     ec_slave_config_t *sc;
280     struct timespec wakeup_time;
281     int ret = 0;
282
283     master = ecrt_request_master(0);
284     if (!master) {
285         return -1;
286     }
287
288     domain1 = ecrt_master_create_domain(master);
289     if (!domain1) {
290         return -1;
291     }
292
293     if (!(sc_ana_in = ecrt_master_slave_config(
294         master, AnaInSlavePos, Beckhoff_EL3102))) {
295         fprintf(stderr, "Failed to get slave configuration.\n");
```

```

296     return -1;
297 }
298
299 printf("Configuring PDOs...\n");
300 if (ecrt_slave_config_pdos(sc_ana_in, EC_END, e13102_synchs)) {
301     fprintf(stderr, "Failed to configure PDOs.\n");
302     return -1;
303 }
304
305 if (!(sc = ecrt_master_slave_config(
306     master, AnaOutSlavePos, Beckhoff_EL4102))) {
307     fprintf(stderr, "Failed to get slave configuration.\n");
308     return -1;
309 }
310
311 if (ecrt_slave_config_pdos(sc, EC_END, e14102_synchs)) {
312     fprintf(stderr, "Failed to configure PDOs.\n");
313     return -1;
314 }
315
316 if (!(sc = ecrt_master_slave_config(
317     master, DigOutSlavePos, Beckhoff_EL2032))) {
318     fprintf(stderr, "Failed to get slave configuration.\n");
319     return -1;
320 }
321
322 if (ecrt_slave_config_pdos(sc, EC_END, e12004_synchs)) {
323     fprintf(stderr, "Failed to configure PDOs.\n");
324     return -1;
325 }
326
327 // Create configuration for bus coupler
328 sc = ecrt_master_slave_config(master, BusCouplerPos, Beckhoff_EK1100);
329 if (!sc) {
330     return -1;
331 }
332
333 if (ecrt_domain_reg_pdo_entry_list(domain1, domain1_regs)) {
334     fprintf(stderr, "PDO entry registration failed!\n");
335     return -1;
336 }
337
338 printf("Activating master...\n");
339 if (ecrt_master_activate(master)) {
340     return -1;
341 }
342
343 if (!(domain1_pd = ecrt_domain_data(domain1))) {
344     return -1;
345 }
346
347 /* Set priority */
348
349 struct sched_param param = {};
350 param.sched_priority = sched_get_priority_max(SCHED_FIFO);
351
352 printf("Using priority %i.\n", param.sched_priority);
353 if (sched_setscheduler(0, SCHED_FIFO, &param) == -1) {
354     perror("sched_setscheduler failed");
355 }
356
357 /* Lock memory */
358
359 if (mlockall(MCL_CURRENT | MCL_FUTURE) == -1) {
360     fprintf(stderr, "Warning: Failed to lock memory: %s\n",
361         strerror(errno));

```

```
362     }
363
364     stack_pEFAULT();
365
366     printf("Starting RT task with dt=%u ns.\n", PERIOD_NS);
367
368     clock_gettime(CLOCK_MONOTONIC, &wakeup_time);
369     wakeup_time.tv_sec += 1; /* start in future */
370     wakeup_time.tv_nsec = 0;
371
372     while (1) {
373         ret = clock_nanosleep(CLOCK_MONOTONIC, TIMER_ABSTIME,
374                               &wakeup_time, NULL);
375         if (ret) {
376             fprintf(stderr, "clock_nanosleep(): %s\n", strerror(ret));
377             break;
378         }
379
380         cyclic_task();
381
382         wakeup_time.tv_nsec += PERIOD_NS;
383         while (wakeup_time.tv_nsec >= NSEC_PER_SEC) {
384             wakeup_time.tv_nsec -= NSEC_PER_SEC;
385             wakeup_time.tv_sec++;
386         }
387     }
388
389     return ret;
390 }
391
392 /*****
```

4 Ethernet Devices

The EtherCAT protocol is based on the Ethernet standard, so a master relies on standard Ethernet hardware to communicate with the bus.

The term *device* is used as a synonym for Ethernet network interface hardware.

Native Ethernet Device Drivers There are native device driver modules (see [section 4.2](#)) that handle Ethernet hardware, which a master can use to connect to an EtherCAT bus. They offer their Ethernet hardware to the master module via the device interface (see [section 4.6](#)) and must be capable to prepare Ethernet devices either for EtherCAT (realtime) operation or for “normal” operation using the kernel’s network stack. The advantage of this approach is that the master can operate nearly directly on the hardware, which allows a high performance. The disadvantage is, that there has to be an EtherCAT-capable version of the original Ethernet driver.

Generic Ethernet Device Driver From master version 1.5, there is a generic Ethernet device driver module (see [section 4.3](#)), that uses the lower layers of the network stack to connect to the hardware. The advantage is, that arbitrary Ethernet hardware can be used for EtherCAT operation, independently of the actual hardware driver (so all Linux Ethernet drivers are supported without modifications). The disadvantage is, that this approach does not support realtime extensions like RTAI, because the Linux network stack is addressed. Moreover the performance is a little worse than the native approach, because the Ethernet frame data have to traverse the network stack.

4.1 Network Driver Basics

EtherCAT relies on Ethernet hardware and the master needs a physical Ethernet device to communicate with the bus. Therefore it is necessary to understand how Linux handles network devices and their drivers, respectively.

Tasks of a Network Driver Network device drivers usually handle the lower two layers of the OSI model, that is the physical layer and the data-link layer. A network device itself natively handles the physical layer issues: It represents the hardware to connect to the medium and to send and receive data in the way, the physical layer

protocol describes. The network device driver is responsible for getting data from the kernel's networking stack and forwarding it to the hardware, that does the physical transmission. If data is received by the hardware respectively, the driver is notified (usually by means of an interrupt) and has to read the data from the hardware memory and forward it to the network stack. There are a few more tasks, a network device driver has to handle, including queue control, statistics and device dependent features.

Driver Startup Usually, a driver searches for compatible devices on module loading. For PCI drivers, this is done by scanning the PCI bus and checking for known device IDs. If a device is found, data structures are allocated and the device is taken into operation.

Interrupt Operation A network device usually provides a hardware interrupt that is used to notify the driver of received frames and success of transmission, or errors, respectively. The driver has to register an interrupt service routine (ISR), that is executed each time, the hardware signals such an event. If the interrupt was thrown by the own device (multiple devices can share one hardware interrupt), the reason for the interrupt has to be determined by reading the device's interrupt register. For example, if the flag for received frames is set, frame data has to be copied from hardware to kernel memory and passed to the network stack.

The `net_device` Structure The driver registers a `net_device` structure for each device to communicate with the network stack and to create a "network interface". In case of an Ethernet driver, this interface appears as `ethX`, where X is a number assigned by the kernel on registration. The `net_device` structure receives events (either from userspace or from the network stack) via several callbacks, which have to be set before registration. Not every callback is mandatory, but for reasonable operation the ones below are needed in any case:

`open()` This function is called when network communication has to be started, for example after a command `ip link set ethX up` from userspace. Frame reception has to be enabled by the driver.

`stop()` The purpose of this callback is to "close" the device, i. e. make the hardware stop receiving frames.

`hard_start_xmit()` This function is called for each frame that has to be transmitted. The network stack passes the frame as a pointer to an `sk_buff` structure ("socket buffer", see below), which has to be freed after sending.

`get_stats()` This call has to return a pointer to the device's `net_device_stats` structure, which permanently has to be filled with frame statistics. This means, that every time a frame is received, sent, or an error happened, the appropriate counter in this structure has to be increased.

The actual registration is done with the `register_netdev()` call, unregistering is done with `unregister_netdev()`.

The netif Interface All other communication in the direction interface → network stack is done via the `netif_*()` calls. For example, on successful device opening, the network stack has to be notified, that it can now pass frames to the interface. This is done by calling `netif_start_queue()`. After this call, the `hard_start_xmit()` callback can be called by the network stack. Furthermore a network driver usually manages a frame transmission queue. If this gets filled up, the network stack has to be told to stop passing further frames for a while. This happens with a call to `netif_stop_queue()`. If some frames have been sent, and there is enough space again to queue new frames, this can be notified with `netif_wake_queue()`. Another important call is `netif_receive_skb()`¹: It passes a frame to the network stack, that was just received by the device. Frame data has to be included in a so-called “socket buffer” for that (see below).

Socket Buffers Socket buffers are the basic data type for the whole network stack. They serve as containers for network data and are able to quickly add data headers and footers, or strip them off again. Therefore a socket buffer consists of an allocated buffer and several pointers that mark beginning of the buffer (`head`), beginning of data (`data`), end of data (`tail`) and end of buffer (`end`). In addition, a socket buffer holds network header information and (in case of received data) a pointer to the `net_device`, it was received on. There exist functions that create a socket buffer (`dev_alloc_skb()`), add data either from front (`skb_push()`) or back (`skb_put()`), remove data from front (`skb_pull()`) or back (`skb_trim()`), or delete the buffer (`kfree_skb()`). A socket buffer is passed from layer to layer, and is freed by the layer that uses it the last time. In case of sending, freeing has to be done by the network driver.

4.2 Native EtherCAT Device Drivers

There are a few requirements, that applies to Ethernet hardware when used with a native Ethernet driver with EtherCAT functionality.

Dedicated Hardware For performance and realtime purposes, the EtherCAT master needs direct and exclusive access to the Ethernet hardware. This implies that the network device must not be connected to the kernel’s network stack as usual, because the kernel would try to use it as an ordinary Ethernet device.

Interrupt-less Operation EtherCAT frames travel through the logical EtherCAT ring and are then sent back to the master. Communication is highly deterministic: A frame is sent and will be received again after a constant time, so there is no need to

¹This function is part of the NAPI (“New API”), that replaces the kernel 2.4 technique for interfacing to the network stack (with `netif_rx()`). NAPI is a technique to improve network performance on Linux. Read more in <http://www.cyberus.ca/~hadi/usenix-paper.tgz>.

notify the driver about frame reception: The master can instead query the hardware for received frames, if it expects them to be already received.

Figure 4.1 shows two workflows for cyclic frame transmission and reception with and without interrupts.

In the left workflow “Interrupt Operation”, the data from the last cycle is first processed and a new frame is assembled with new datagrams, which is then sent. The cyclic work is done for now. Later, when the frame is received again by the hardware, an interrupt is triggered and the ISR is executed. The ISR will fetch the frame data from the hardware and initiate the frame dissection: The datagrams will be processed, so that the data is ready for processing in the next cycle.

In the right workflow “Interrupt-less Operation”, there is no hardware interrupt enabled. Instead, the hardware will be polled by the master by executing the ISR. If the frame has been received in the meantime, it will be dissected. The situation is now the same as at the beginning of the left workflow: The received data is processed and a new frame is assembled and sent. There is nothing to do for the rest of the cycle.

The interrupt-less operation is desirable, because hardware interrupts are not conducive in improving the driver’s realtime behaviour: Their indeterministic incidences contribute to increasing the jitter. Besides, if a realtime extension (like RTAI) is used, some additional effort would have to be made to prioritize interrupts.

Ethernet and EtherCAT Devices Another issue lies in the way Linux handles devices of the same type. For example, a PCI driver scans the PCI bus for devices it can handle. Then it registers itself as the responsible driver for all of the devices found. The problem is, that an unmodified driver can not be told to ignore a device because it will be used for EtherCAT later. There must be a way to handle multiple devices of the same type, where one is reserved for EtherCAT, while the other is treated as an ordinary Ethernet device.

For all this reasons, the author decided that the only acceptable solution is to modify standard Ethernet drivers in a way that they keep their normal functionality, but gain the ability to treat one or more of the devices as EtherCAT-capable.

Below are the advantages of this solution:

- No need to tell the standard drivers to ignore certain devices.
- One networking driver for EtherCAT and non-EtherCAT devices.
- No need to implement a network driver from scratch and running into issues, the former developers already solved.

The chosen approach has the following disadvantages:

- The modified driver gets more complicated, as it must handle EtherCAT and non-EtherCAT devices.
- Many additional case differentiations in the driver code.
- Changes and bug fixes on the standard drivers have to be ported to the EtherCAT-capable versions from time to time.

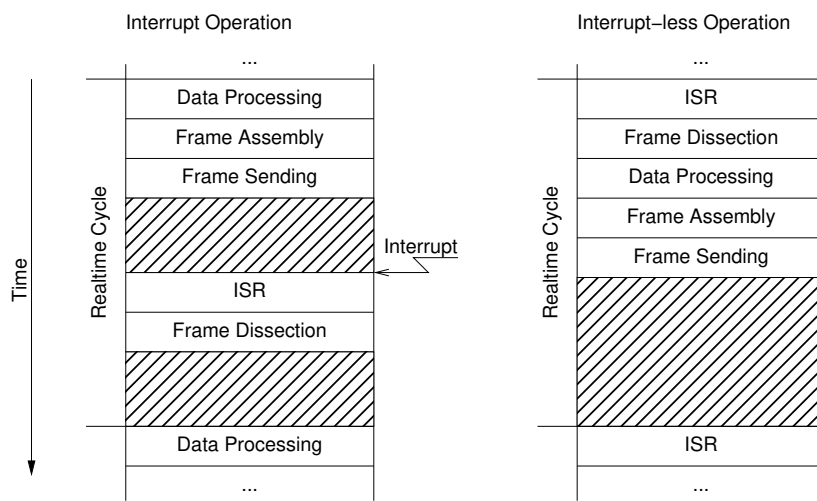

Figure 4.1: Interrupt Operation versus Interrupt-less Operation

4.3 Generic EtherCAT Device Driver

Since there are approaches to enable the complete Linux kernel for realtime operation [12], it is possible to operate without native implementations of EtherCAT-capable Ethernet device drivers and use the Linux network stack instead. Figure 2.1 shows the “Generic Ethernet Driver Module”, that connects to local Ethernet devices via the network stack. The kernel module is named `ec_generic` and can be loaded after the master module like a native EtherCAT-capable Ethernet driver.

The generic device driver scans the network stack for interfaces, that have been registered by Ethernet device drivers. It offers all possible devices to the EtherCAT master. If the master accepts a device, the generic driver creates a packet socket (see `man 7 packet`) with `socket_type` set to `SOCK_RAW`, bound to that device. All functions of the device interface (see section 4.6) will then operate on that socket.

Below are the advantages of this solution:

- Any Ethernet hardware, that is covered by a Linux Ethernet driver can be used for EtherCAT.
- No modifications have to be made to the actual Ethernet drivers.

The generic approach has the following disadvantages:

- The performance is a little worse than the native approach, because the frame data have to traverse the lower layers of the network stack.
- It is not possible to use in-kernel realtime extensions like RTAI with the generic driver, because the network stack code uses dynamic memory allocations and other things, that could cause the system to freeze in realtime context.

Device Activation In order to send and receive frames through a socket, the Ethernet device linked to that socket has to be activated, otherwise all frames will be rejected. Activation has to take place before the master module is loaded and can happen in several ways:

- Ad-hoc, using the command `ip link set dev ethX up` (or the older `ifconfig ethX up`),
- Configured, depending on the distribution, for example using `ifcfg` files (`/etc/sysconfig/network/ifcfg-ethX`) in openSUSE and others. This is the better choice, if the EtherCAT master shall start at system boot time. Since the Ethernet device shall only be activated, but no IP address etc. shall be assigned, it is enough to use `STARTMODE=auto` as configuration.

4.4 Providing Ethernet Devices

After loading the master module, additional module(s) have to be loaded to offer devices to the master(s) (see [section 4.6](#)). The master module knows the devices to choose from the module parameters (see [section 2.1](#)). If the init script is used to start the master, the drivers and devices to use can be specified in the sysconfig file (see [subsection 7.4.2](#)).

Modules offering Ethernet devices can be

- native EtherCAT-capable network driver modules (see [section 4.2](#)) or
- the generic EtherCAT device driver module (see [section 4.3](#)).

4.5 Redundancy

Redundant bus operation means, that there is more than one Ethernet connection from the master to the slaves. Process data exchange datagrams are sent out on every master link, so that the exchange is still complete, even if the bus is disconnected somewhere in between.

Prerequisite for fully redundant bus operation is, that every slave can be reached by at least one master link. In this case a single connection failure (i. e. cable break) will never lead to incomplete process data. Double-faults can not be handled with two Ethernet devices.

Redundancy is configured with the `--with-devices` switch at configure time (see [chapter 9](#)) and using the `backup_devices` parameter of the `ec_master` kernel module (see [section 2.1](#)) or the appropriate variable `MASTERx_BACKUP` in the (sys-)config file (see [subsection 7.4.2](#)).

Bus scanning is done after a topology change on any Ethernet link. The application interface (see [chapter 3](#)) and the command-line tool (see [section 7.1](#)) both have methods to query the status of the redundant operation.

4.6 EtherCAT Device Interface

An anticipation to the section about the master module ([section 2.1](#)) has to be made in order to understand the way, a network device driver module can connect a device to a specific EtherCAT master.

The master module provides a “device interface” for network device drivers. To use this interface, a network device driver module must include the header `devices/ecdev.h`, coming with the EtherCAT master code. This header offers a function interface for EtherCAT devices. All functions of the device interface are named with the prefix `ecdev`.

The documentation of the device interface can be found in the header file or in the appropriate module of the interface documentation (see [section 9.3](#) for generation instructions).

4.7 Patching Native Network Drivers

This section will describe, how to make a standard Ethernet driver EtherCAT-capable, using the native approach (see [section 4.2](#)). Unfortunately, there is no standard procedure to enable an Ethernet driver for use with the EtherCAT master, but there are a few common techniques.

1. A first simple rule is, that `netif_*()` calls must be avoided for all EtherCAT devices. As mentioned before, EtherCAT devices have no connection to the network stack, and therefore must not call its interface functions.
2. Another important thing is, that EtherCAT devices should be operated without interrupts. So any calls of registering interrupt handlers and enabling interrupts at hardware level must be avoided, too.
3. The master does not use a new socket buffer for each send operation: Instead there is a fix one allocated on master initialization. This socket buffer is filled with an EtherCAT frame with every send operation and passed to the `hard_start_xmit()` callback. For that it is necessary, that the socket buffer is not be freed by the network driver as usual.

An Ethernet driver usually handles several Ethernet devices, each described by a `net_device` structure with a `priv_data` field to attach driver-dependent data to the structure. To distinguish between normal Ethernet devices and the ones used by EtherCAT masters, the private data structure used by the driver could be extended by a pointer, that points to an `ec_device_t` object returned by `ecdev_offer()` (see [section 4.6](#)) if the device is used by a master and otherwise is zero.

The RealTek RTL-8139 Fast Ethernet driver is a “simple” Ethernet driver and can be taken as an example to patch new drivers. The interesting sections can be found by searching the string “ecdev” in the file `devices/8139too-2.6.24-ethercat.c`.

5 State Machines

Many parts of the EtherCAT master are implemented as *finite state machines* (FSMs). Though this leads to a higher grade of complexity in some aspects, it opens many new possibilities.

The below short code example exemplary shows how to read all slave states and moreover illustrates the restrictions of “sequential” coding:

```
1 ec_datagram_brd(datagram, 0x0130, 2); // prepare datagram
2 if (ec_master_simple_io(master, datagram)) return -1;
3 slave_states = EC_READ_U8(datagram->data); // process datagram
```

The `ec_master_simple_io()` function provides a simple interface for synchronously sending a single datagram and receiving the result¹. Internally, it queues the specified datagram, invokes the `ec_master_send_datagrams()` function to send a frame with the queued datagram and then waits actively for its reception.

This sequential approach is very simple, reflecting in only three lines of code. The disadvantage is, that the master is blocked for the time it waits for datagram reception. There is no difficulty when only one instance is using the master, but if more instances want to (synchronously²) use the master, it is inevitable to think about an alternative to the sequential model.

Master access has to be sequentialized for more than one instance wanting to send and receive datagrams synchronously. With the present approach, this would result in having one phase of active waiting for each instance, which would be non-acceptable especially in realtime circumstances, because of the huge time overhead.

A possible solution is, that all instances would be executed sequentially to queue their datagrams, then give the control to the next instance instead of waiting for the datagram reception. Finally, bus IO is done by a higher instance, which means that all queued datagrams are sent and received. The next step is to execute all instances again, which then process their received datagrams and issue new ones.

This approach results in all instances having to retain their state, when giving the control back to the higher instance. It is quite obvious to use a *finite state machine* model in this case. [section 5.1](#) will introduce some of the theory used, while the

¹For all communication issues have been meanwhile sourced out into state machines, the function is deprecated and stopped existing. Nevertheless it is adequate for showing its own restrictions.

²At this time, synchronous master access will be adequate to show the advantages of an FSM. The asynchronous approach will be discussed in [section 6.1](#)

listings below show the basic approach by coding the example from above as a state machine:

```
1 // state 1
2 ec_datagram_brd(datagram, 0x0130, 2); // prepare datagram
3 ec_master_queue(master, datagram); // queue datagram
4 next_state = state_2;
5 // state processing finished
```

After all instances executed their current state and queued their datagrams, these are sent and received. Then the respective next states are executed:

```
1 // state 2
2 if (datagram->state != EC_DGRAM_STATE_RECEIVED) {
3     next_state = state_error;
4     return; // state processing finished
5 }
6 slave_states = EC_READ_U8(datagram->data); // process datagram
7 // state processing finished.
```

See [section 5.2](#) for an introduction to the state machine programming concept used in the master code.

5.1 State Machine Theory

A finite state machine [9] is a model of behavior with inputs and outputs, where the outputs not only depend on the inputs, but the history of inputs. The mathematical definition of a finite state machine (or finite automaton) is a six-tuple $(\Sigma, \Gamma, S, s_0, \delta, \omega)$, with

- the input alphabet Σ , with $\Sigma \neq \emptyset$, containing all input symbols,
- the output alphabet Γ , with $\Gamma \neq \emptyset$, containing all output symbols,
- the set of states S , with $S \neq \emptyset$,
- the set of initial states s_0 with $s_0 \subseteq S, s_0 \neq \emptyset$
- the transition function $\delta : S \times \Sigma \rightarrow S \times \Gamma$
- the output function ω .

The state transition function δ is often specified by a *state transition table*, or by a *state transition diagram*. The transition table offers a matrix view of the state machine behavior (see [Table 5.1](#)). The matrix rows correspond to the states ($S = \{s_0, s_1, s_2\}$) and the columns correspond to the input symbols ($\Gamma = \{a, b, \varepsilon\}$). The table contents in a certain row i and column j then represent the next state (and possibly the output) for the case, that a certain input symbol σ_j is read in the state s_i .

Table 5.1: A typical state transition table

	a	b	ε
s_0	s_1	s_1	s_2
s_1	s_2	s_1	s_0
s_2	s_0	s_0	s_0

The state diagram for the same example looks like the one in [Figure 5.1](#). The states are represented as circles or ellipses and the transitions are drawn as arrows between them. Close to a transition arrow can be the condition that must be fulfilled to allow the transition. The initial state is marked by a filled black circle with an arrow pointing to the respective state.

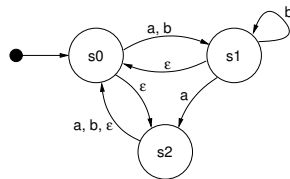

Figure 5.1: A typical state transition diagram

Deterministic and non-deterministic state machines A state machine can be deterministic, meaning that for one state and input, there is one (and only one) following state. In this case, the state machine has exactly one starting state. Non-deterministic state machines can have more than one transitions for a single state-input combination. There is a set of starting states in the latter case.

Moore and Mealy machines There is a distinction between so-called *Moore machines*, and *Mealy machines*. Mathematically spoken, the distinction lies in the output function ω : If it only depends on the current state ($\omega : S \rightarrow \Gamma$), the machine corresponds to the “Moore Model”. Otherwise, if ω is a function of a state and the input alphabet ($\omega : S \times \Sigma \rightarrow \Gamma$) the state machine corresponds to the “Mealy model”. Mealy machines are the more practical solution in most cases, because their design allows machines with a minimum number of states. In practice, a mixture of both models is often used.

Misunderstandings about state machines There is a phenomenon called “state explosion”, that is often taken as a counter-argument against general use of state machines in complex environments. It has to be mentioned, that this point is misleading [10]. State explosions happen usually as a result of a bad state machine design: Common mistakes are storing the present values of all inputs in a state, or not dividing a complex state machine into simpler sub state machines. The EtherCAT master uses several state machines, that are executed hierarchically and so serve as sub state machines. These are also described below.

5.2 The Master’s State Model

This section will introduce the techniques used in the master to implement state machines.

State Machine Programming There are certain ways to implement a state machine in *C* code. An obvious way is to implement the different states and actions by one big case differentiation:

```
1 enum {STATE_1, STATE_2, STATE_3};
2 int state = STATE_1;
3
4 void state_machine_run(void *priv_data) {
5     switch (state) {
6         case STATE_1:
7             action_1();
8             state = STATE_2;
9             break;
10        case STATE_2:
11            action_2()
12            if (some_condition) state = STATE_1;
13            else state = STATE_3;
14            break;
15        case STATE_3:
16            action_3();
```

```

17             state = STATE_1;
18             break;
19         }
20     }

```

For small state machines, this is an option. The disadvantage is, that with an increasing number of states the code soon gets complex and an additional case differentiation is executed each run. Besides, lots of indentation is wasted.

The method used in the master is to implement every state in an own function and to store the current state function with a function pointer:

```

1 void (*state)(void *) = state1;
2
3 void state_machine_run(void *priv_data) {
4     state(priv_data);
5 }
6
7 void state1(void *priv_data) {
8     action_1();
9     state = state2;
10 }
11
12 void state2(void *priv_data) {
13     action_2();
14     if (some_condition) state = state1;
15     else state = state2;
16 }
17
18 void state3(void *priv_data) {
19     action_3();
20     state = state1;
21 }

```

In the master code, state pointers of all state machines³ are gathered in a single object of the `ec_fsm_master_t` class. This is advantageous, because there is always one instance of every state machine available and can be started on demand.

Mealy and Moore If a closer look is taken to the above listing, it can be seen that the actions executed (the “outputs” of the state machine) only depend on the current state. This accords to the “Moore” model introduced in [section 5.1](#). As mentioned, the “Mealy” model offers a higher flexibility, which can be seen in the listing below:

```

1 void state7(void *priv_data) {

```

³All except for the EoE state machine, because multiple EoE slaves have to be handled in parallel. For this reason each EoE handler object has its own state pointer.

```
2         if (some_condition) {
3             action_7a();
4             state = state1;
5         }
6         else {
7             action_7b();
8             state = state8;
9         }
10    }
```

③ + ⑦ The state function executes the actions depending on the state transition, that is about to be done.

The most flexible alternative is to execute certain actions depending on the state, followed by some actions dependent on the state transition:

```
1 void state9(void *priv_data) {
2     action_9();
3     if (some_condition) {
4         action_9a();
5         state = state7;
6     }
7     else {
8         action_9b();
9         state = state10;
10    }
11 }
```

This model is often used in the master. It combines the best aspects of both approaches.

Using Sub State Machines To avoid having too much states, certain functions of the EtherCAT master state machine have been sourced out into sub state machines. This helps to encapsulate the related workflows and moreover avoids the “state explosion” phenomenon described in [section 5.1](#). If the master would instead use one big state machine, the number of states would be a multiple of the actual number. This would increase the level of complexity to a non-manageable grade.

Executing Sub State Machines If a state machine starts to execute a sub state machine, it usually remains in one state until the sub state machine terminates. This is usually done like in the listing below, which is taken out of the slave configuration state machine code:

```
1 void ec_fsm_slaveconf_safeop(ec_fsm_t *fsm)
2 {
3     fsm->change_state(fsm); // execute state change
```

```

4           // sub state machine
5
6       if (fsm->change_state == ec_fsm_error) {
7           fsm->slave_state = ec_fsm_end;
8           return;
9       }
10
11      if (fsm->change_state != ec_fsm_end) return;
12
13      // continue state processing
14      ...

```

- ③ `change_state` is the state pointer of the state change state machine. The state function, the pointer points on, is executed. . .
- ⑥ . . . either until the state machine terminates with the error state . . .
- ⑪ . . . or until the state machine terminates in the end state. Until then, the “higher” state machine remains in the current state and executes the sub state machine again in the next cycle.

State Machine Descriptions The below sections describe every state machine used in the EtherCAT master. The textual descriptions of the state machines contain references to the transitions in the corresponding state transition diagrams, that are marked with an arrow followed by the name of the successive state. Transitions caused by trivial error cases (i. e. no response from slave) are not described explicitly. These transitions are drawn as dashed arrows in the diagrams.

5.3 The Master State Machine

The master state machine is executed in the context of the master thread. [Figure 5.2](#) shows its transition diagram. Its purposes are:

Bus monitoring The bus topology is monitored. If it changes, the bus is (re-)scanned.

Slave configuration The application-layer states of the slaves are monitored. If a slave is not in the state it supposed to be, the slave is (re-)configured.

Request handling Requests (either originating from the application or from external sources) are handled. A request is a job that the master shall process asynchronously, for example an SII access, SDO access, or similar.

5.4 The Slave Scan State Machine

The slave scan state machine, which can be seen in [Figure 5.3](#), leads through the process of reading desired slave information.

The scan process includes the following steps:

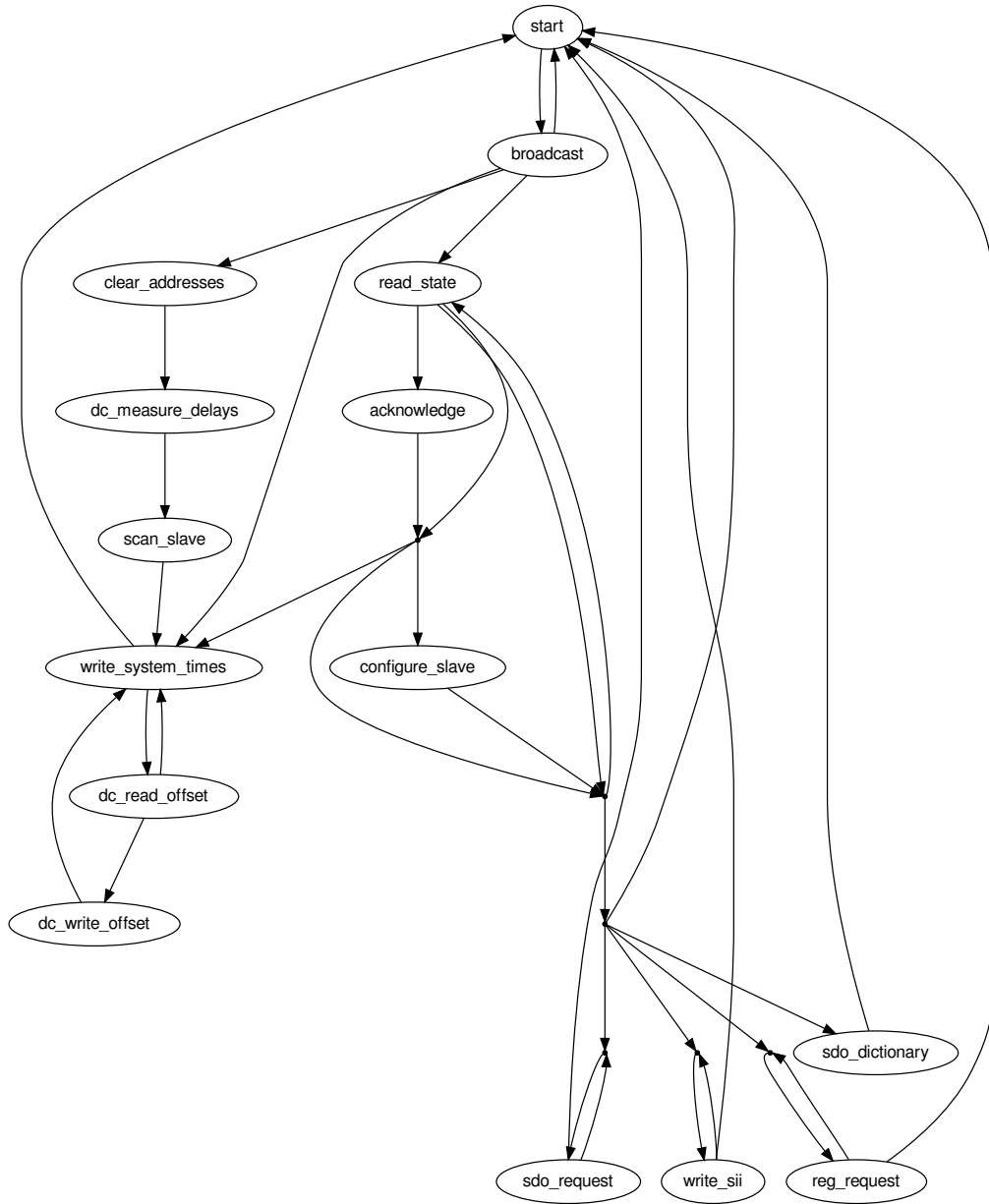

Figure 5.2: Transition diagram of the master state machine

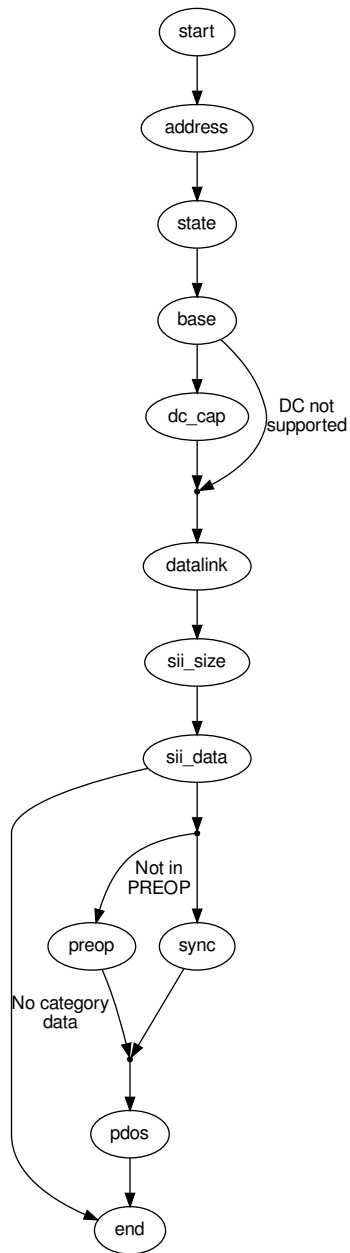

Figure 5.3: Transition diagram of the slave scan state machine

Node Address The node address is set for the slave, so that it can be node-addressed for all following operations.

AL State The initial application-layer state is read.

Base Information Base information (like the number of supported FMMUs) is read from the lower physical memory.

Data Link Information about the physical ports is read.

SII Size The size of the SII contents is determined to allocate SII image memory.

SII Data The SII contents are read into the master's image.

PREOP If the slave supports CoE, it is set to PREOP state using the State change FSM (see [section 5.6](#)) to enable mailbox communication and read the PDO configuration via CoE.

PDOs The PDOs are read via CoE (if supported) using the PDO Reading FSM (see [section 5.8](#)). If this is successful, the PDO information from the SII (if any) is overwritten.

5.5 The Slave Configuration State Machine

The slave configuration state machine, which can be seen in [Figure 5.4](#), leads through the process of configuring a slave and bringing it to a certain application-layer state.

INIT The state change FSM is used to bring the slave to the INIT state.

FMMU Clearing To avoid that the slave reacts on any process data, the FMMU configuration are cleared. If the slave does not support FMMUs, this state is skipped. If INIT is the requested state, the state machine is finished.

Mailbox Sync Manager Configuration If the slaves support mailbox communication, the mailbox sync managers are configured. Otherwise this state is skipped.

PREOP The state change FSM is used to bring the slave to PREOP state. If this is the requested state, the state machine is finished.

SDO Configuration If there is a slave configuration attached (see [section 3.1](#)), and there are any SDO configurations that are provided by the application, these are sent to the slave.

PDO Configuration The PDO configuration state machine is executed to apply all necessary PDO configurations.

PDO Sync Manager Configuration If any PDO sync managers exist, they are configured.

FMMU Configuration If there are FMMUs configurations supplied by the application (i. e. if the application registered PDO entries), they are applied.

SAFEOP The state change FSM is used to bring the slave to SAFEOP state. If this is the requested state, the state machine is finished.

OP The state change FSM is used to bring the slave to OP state. If this is the requested state, the state machine is finished.

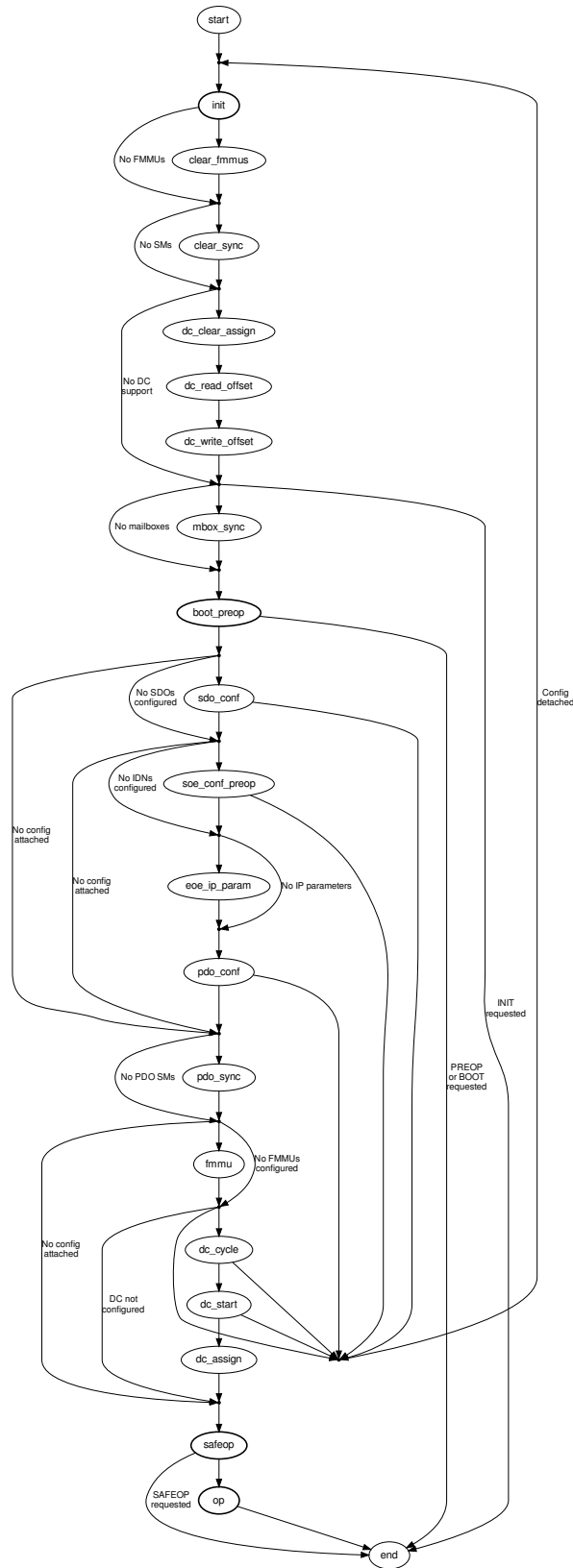

Figure 5.4: Transition diagram of the slave configuration state machine

5.6 The State Change State Machine

The state change state machine, which can be seen in [Figure 5.5](#), leads through the process of changing a slave’s application-layer state. This implements the states and transitions described in [\[3, sec. 6.4.1\]](#).

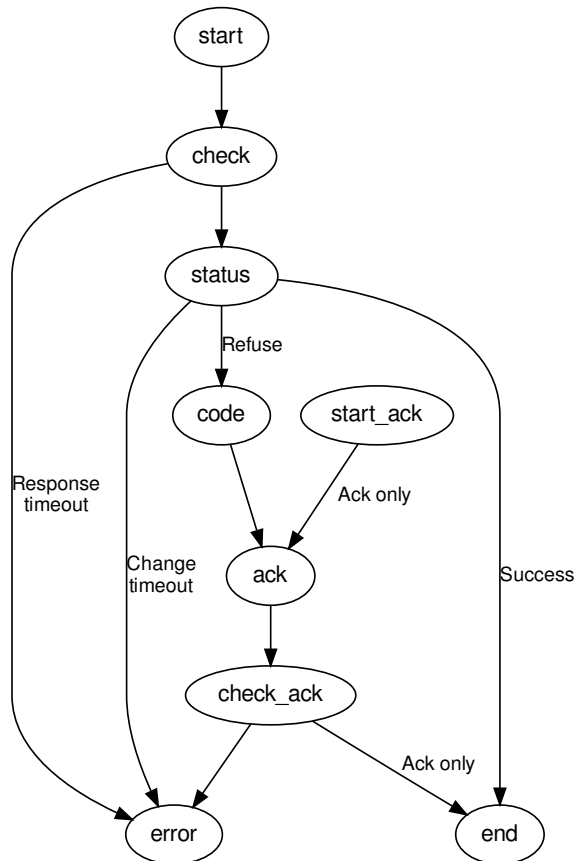

Figure 5.5: Transition Diagram of the State Change State Machine

Start The new application-layer state is requested via the “AL Control Request” register (see [\[3, sec. 5.3.1\]](#)).

Check for Response Some slave need some time to respond to an AL state change command, and do not respond for some time. For this case, the command is issued again, until it is acknowledged.

Check AL Status If the AL State change datagram was acknowledged, the “AL Control Response” register (see [\[3, sec. 5.3.2\]](#)) must be read out until the slave changes the AL state.

AL Status Code If the slave refused the state change command, the reason can be read from the “AL Status Code” field in the “AL State Changed” registers (see [3, sec. 5.3.3]).

Acknowledge State If the state change was not successful, the master has to acknowledge the old state by writing to the “AL Control request” register again.

Check Acknowledge After sending the acknowledge command, it has to read out the “AL Control Response” register again.

The “start_ack” state is a shortcut in the state machine for the case, that the master wants to acknowledge a spontaneous AL state change, that was not requested.

5.7 The SII State Machine

The SII state machine (shown in Figure 5.6) implements the process of reading or writing SII data via the Slave Information Interface described in [2, sec. 6.4].

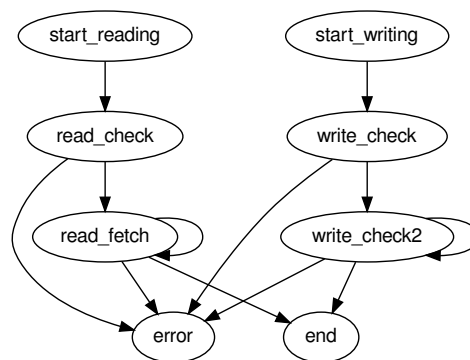

Figure 5.6: Transition Diagram of the SII State Machine

This is how the reading part of the state machine works:

Start Reading The read request and the requested word address are written to the SII attribute.

Check Read Command If the SII read request command has been acknowledged, a timer is started. A datagram is issued, that reads out the SII attribute for state and data.

Fetch Data If the read operation is still busy (the SII is usually implemented as an E²PROM), the state is read again. Otherwise the data are copied from the datagram.

The writing part works nearly similar:

Start Writing A write request, the target address and the data word are written to the SII attribute.

Check Write Command If the SII write request command has been acknowledged, a timer is started. A datagram is issued, that reads out the SII attribute for the state of the write operation.

Wait while Busy If the write operation is still busy (determined by a minimum wait time and the state of the busy flag), the state machine remains in this state to avoid that another write operation is issued too early.

5.8 The PDO State Machines

The PDO state machines are a set of state machines that read or write the PDO assignment and the PDO mapping via the “CoE Communication Area” described in [3, sec. 5.6.7.4]. For the object access, the CANopen over EtherCAT access primitives are used (see section 6.2), so the slave must support the CoE mailbox protocol.

PDO Reading FSM This state machine (Figure 5.7) has the purpose to read the complete PDO configuration of a slave. It reads the PDO assignment for each Sync Manager and uses the PDO Entry Reading FSM (Figure 5.8) to read the mapping for each assigned PDO.

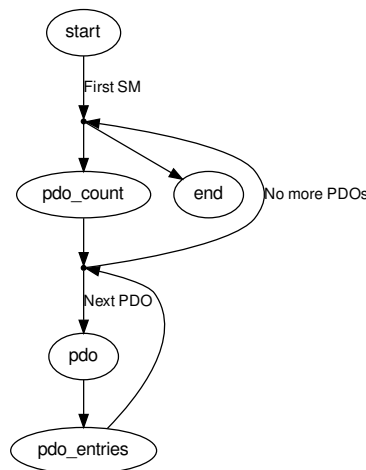

Figure 5.7: Transition Diagram of the PDO Reading State Machine

Basically it reads the every Sync manager’s PDO assignment SDO’s (0x1C1x) number of elements to determine the number of assigned PDOs for this sync manager and then reads out the subindices of the SDO to get the assigned PDO’s indices. When

a PDO index is read, the PDO Entry Reading FSM is executed to read the PDO's mapped PDO entries.

PDO Entry Reading FSM This state machine (Figure 5.8) reads the PDO mapping (the PDO entries) of a PDO. It reads the respective mapping SDO (0x1600 – 0x17ff, or 0x1a00 – 0x1bff) for the given PDO by reading first the subindex zero (number of elements) to determine the number of mapped PDO entries. After that, each subindex is read to get the mapped PDO entry index, subindex and bit size.

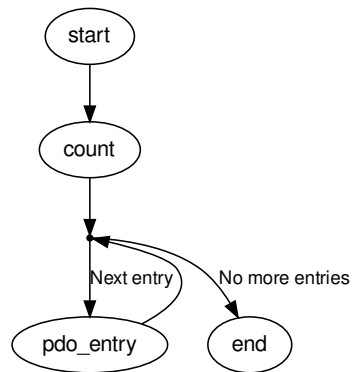

Figure 5.8: Transition Diagram of the PDO Entry Reading State Machine

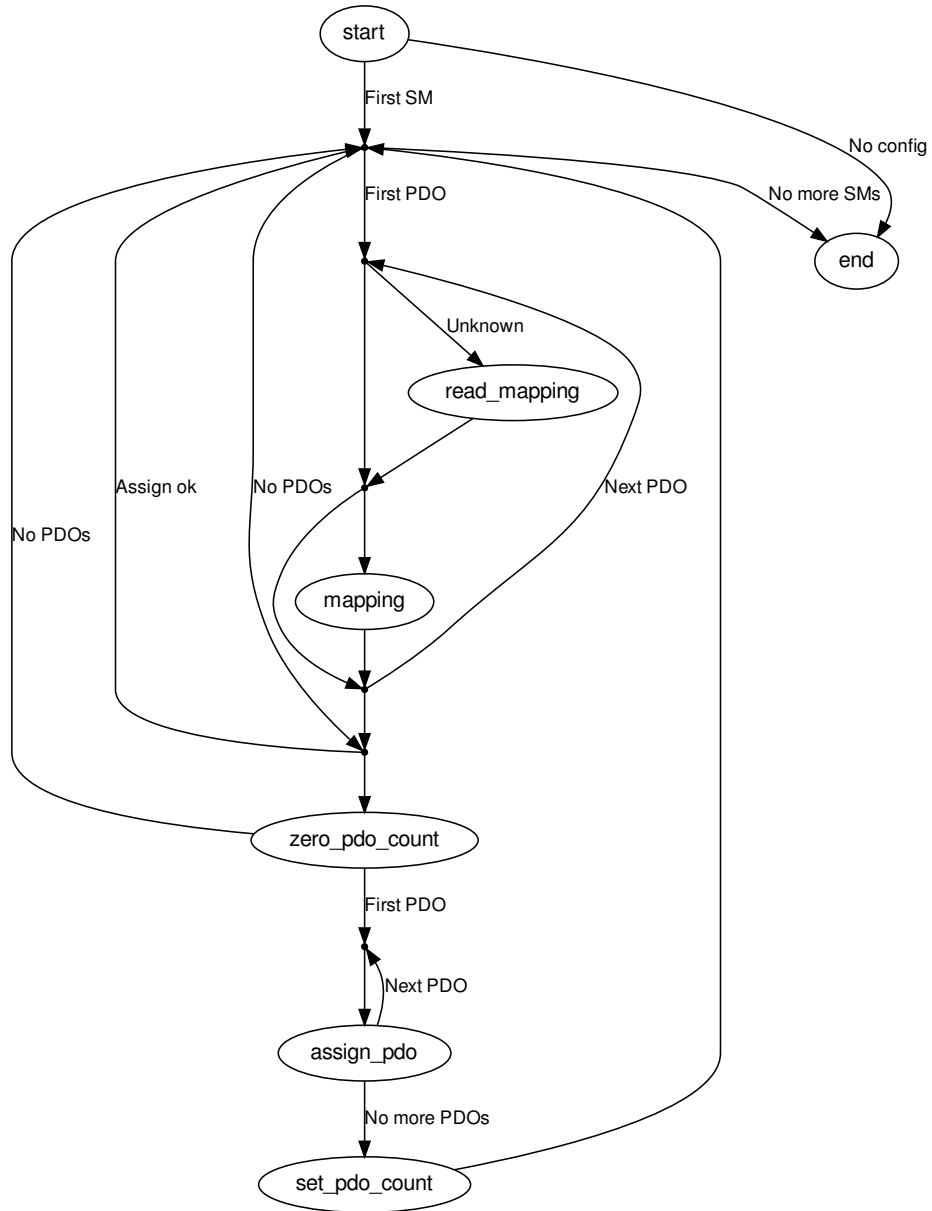

Figure 5.9: Transition Diagram of the PDO Configuration State Machine

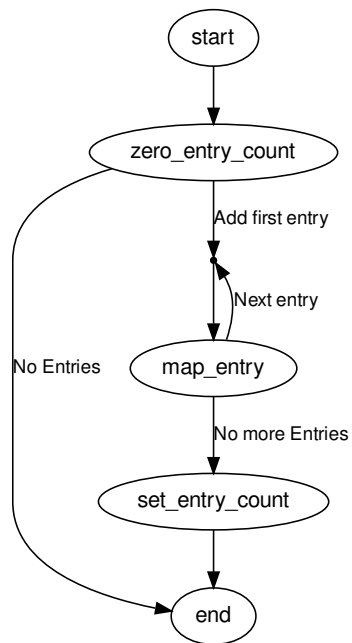

Figure 5.10: Transition Diagram of the PDO Entry Configuration State Machine

6 Mailbox Protocol Implementations

The EtherCAT master implements the CANopen over EtherCAT (CoE), Ethernet over EtherCAT (EoE), File-access over EtherCAT (FoE), Vendor-specific over EtherCAT (VoE) and Servo Profile over EtherCAT (SoE) mailbox protocols. See the below sections for details.

6.1 Ethernet over EtherCAT (EoE)

The EtherCAT master implements the Ethernet over EtherCAT mailbox protocol [3, sec. 5.7] to enable the tunneling of Ethernet frames to special slaves, that can either have physical Ethernet ports to forward the frames to, or have an own IP stack to receive the frames.

Virtual Network Interfaces The master creates a virtual EoE network interface for every EoE-capable slave. These interfaces are called either

eoexsY for a slave without an alias address (see [subsection 7.1.2](#)), where X is the master index and Y is the slave's ring position, or

eoexaY for a slave with a non-zero alias address, where X is the master index and Y is the decimal alias address.

For some hints on how to configure these virtual interfaces, see [subsection 6.1.1](#).

Frames sent to these interfaces are forwarded to the associated slaves by the master. Frames, that are received by the slaves, are fetched by the master and forwarded to the virtual interfaces.

This bears the following advantages:

- Flexibility: The user can decide, how the EoE-capable slaves are interconnected with the rest of the world.
- Standard tools can be used to monitor the EoE activity and to configure the EoE interfaces.
- The Linux kernel's layer-2-bridging implementation (according to the IEEE 802.1D MAC Bridging standard) can be used natively to bridge Ethernet traffic between EoE-capable slaves.
- The Linux kernel's network stack can be used to route packets between EoE-capable slaves and to track security issues, just like having physical network interfaces.

EoE Handlers The virtual EoE interfaces and the related functionality is encapsulated in the `ec_eoe_t` class. An object of this class is called “EoE handler”. For example the master does not create the network interfaces directly: This is done inside the constructor of an EoE handler. An EoE handler additionally contains a frame queue. Each time, the kernel passes a new socket buffer for sending via the interface’s `hard_start_xmit()` callback, the socket buffer is queued for transmission by the EoE state machine (see below). If the queue gets filled up, the passing of new socket buffers is suspended with a call to `netif_stop_queue()`.

Creation of EoE Handlers During bus scanning (see [section 5.4](#)), the master determines the supported mailbox protocols for each slave. This is done by examining the “Supported Mailbox Protocols” mask field at word address 0x001C of the SII. If bit 1 is set, the slave supports the EoE protocol. In this case, an EoE handler is created for that slave.

EoE State Machine Every EoE handler owns an EoE state machine, that is used to send frames to the corresponding slave and receive frames from the it via the EoE communication primitives. This state machine is showed in [Figure 6.1](#).

RX_START The beginning state of the EoE state machine. A mailbox check datagram is sent, to query the slave’s mailbox for new frames. → `RX_CHECK`

RX_CHECK The mailbox check datagram is received. If the slave’s mailbox did not contain data, a transmit cycle is started. → `TX_START`

If there are new data in the mailbox, a datagram is sent to fetch the new data.
→ `RX_FETCH`

RX_FETCH The fetch datagram is received. If the mailbox data do not contain a “EoE Fragment request” command, the data are dropped and a transmit sequence is started. → `TX_START`

If the received Ethernet frame fragment is the first fragment, a new socket buffer is allocated. In either case, the data are copied into the correct position of the socket buffer.

If the fragment is the last fragment, the socket buffer is forwarded to the network stack and a transmit sequence is started. → `TX_START`

Otherwise, a new receive sequence is started to fetch the next fragment. → `RX_START`

TX_START The beginning state of a transmit sequence. It is checked, if the transmission queue contains a frame to send. If not, a receive sequence is started. → `RX_START`

If there is a frame to send, it is dequeued. If the queue was inactive before (because it was full), the queue is woken up with a call to `netif_wake_queue()`. The first fragment of the frame is sent. → `TX_SENT`

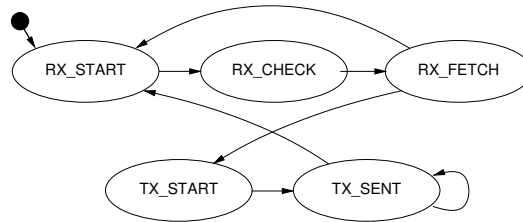

Figure 6.1: Transition Diagram of the EoE State Machine

TX_SENT It is checked, if the first fragment was sent successfully. If the current frame consists of further fragments, the next one is sent. → TX_SENT

If the last fragment was sent, a new receive sequence is started. → RX_START

EoE Processing To execute the EoE state machine of every active EoE handler, there must be a cyclic process. The easiest solution would be to execute the EoE state machines synchronously with the master state machine (see [section 5.3](#)). This approach has the following disadvantage:

Only one EoE fragment could be sent or received every few cycles. This causes the data rate to be very low, because the EoE state machines are not executed in the time between the application cycles. Moreover, the data rate would be dependent on the period of the application task.

To overcome this problem, an own cyclic process is needed to asynchronously execute the EoE state machines. For that, the master owns a kernel timer, that is executed each timer interrupt. This guarantees a constant bandwidth, but poses the new problem of concurrent access to the master. The locking mechanisms needed for this are introduced in [section 3.4](#).

6.1.1 EoE Interface Configuration

The configuration of the EoE network interfaces is a matter of using standard Linux networking infrastructure commands like `ifconfig`, `ip` and `brctl`. Though this lies not in the scope of this document, some hints and examples are provided in this section.

In the below examples it is assumed, that there are two slaves (0 and 1) with EoE support in the bus. The first decision to make is whether to use a bridged or routed environment.

Bridging A common solution is to create a bridge containing all EoE interfaces:

```
$ brctl addbr br0
$ ip addr add 192.168.100.1/24 dev br0
$ brctl addif br0 eoe0s0
$ brctl addif br0 eoe0s1
```

The above example allows to access IPv4 nodes using subnet 192.168.100.0/24 connected to the EtherCAT bus via EoE. Please note, that the example only contains ad-hoc configuration commands: If the bus topology changes, the EoE interfaces are re-created and have to be added to the bridge again. Therefore it is highly recommended to use the networking configuration infrastructure of the used Linux distribution to store this configuration permanently, so that appearing EoE devices are added automatically.

Routing Another possibility is to create an IP subnet for each EoE interface:

```
$ ip addr add 192.168.200.1/24 dev eoe0s0
$ ip addr add 192.168.201.1/24 dev eoe0s1
$ echo 1 > /proc/sys/net/ipv4/ip_forward
```

This example is again only an ad-hoc configuration (see above). Please note, that it is necessary to set the default gateways properly on the IP nodes connected to the EoE slaves, if they shall be able to communicate between the different EoE interfaces / IP networks.

Setting IP Parameters If IP address and other parameters of the EoE remote nodes (not the EoE interfaces on the master side) have to be set, this can be achieved via the `ethercat ip` command-line tool (see [subsection 7.1.13](#)).

6.2 CANopen over EtherCAT (CoE)

The CANopen over EtherCAT protocol [3, sec. 5.6] is used to configure slaves and exchange data objects on application level.

SDO Download State Machine The best time to apply SDO configurations is during the slave’s PREOP state, because mailbox communication is already possible and slave’s application will start with updating input data in the succeeding SAFEOP state. Therefore the SDO configuration has to be part of the slave configuration state machine (see [section 5.5](#)): It is implemented via an SDO download state machine, that is executed just before entering the slave’s SAFEOP state. In this way, it is guaranteed that the SDO configurations are applied each time, the slave is reconfigured.

The transition diagram of the SDO Download state machine can be seen in [Figure 6.2](#).

START The beginning state of the CoE download state machine. The “SDO Download Normal Request” mailbox command is sent. → REQUEST

REQUEST It is checked, if the CoE download request has been received by the slave. After that, a mailbox check command is issued and a timer is started. → CHECK

CHECK If no mailbox data is available, the timer is checked.

- If it timed out, the SDO download is aborted. → ERROR
- Otherwise, the mailbox is queried again. → CHECK

If the mailbox contains new data, the response is fetched. → RESPONSE

RESPONSE If the mailbox response could not be fetched, the data is invalid, the wrong protocol was received, or a “Abort SDO Transfer Request” was received, the SDO download is aborted. → ERROR

If a “SDO Download Normal Response” acknowledgement was received, the SDO download was successful. → END

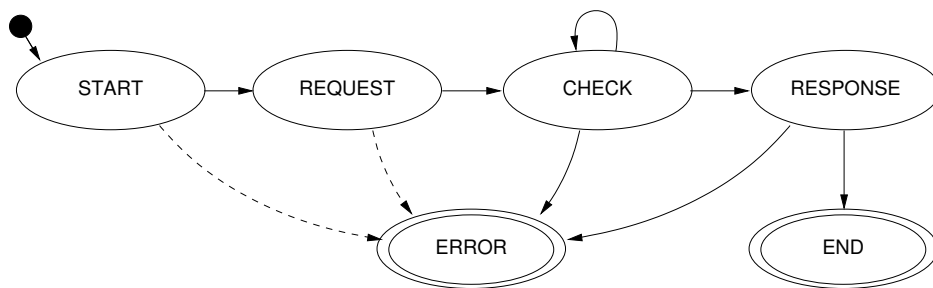

Figure 6.2: Transition diagram of the CoE download state machine

END The SDO download was successful.

ERROR The SDO download was aborted due to an error.

6.3 Vendor specific over EtherCAT (VoE)

The VoE protocol opens the possibility to implement a vendor-specific mailbox communication protocol. VoE mailbox messages are prepended by a VoE header containing a 32-bit vendor ID and a 16-bit vendor-type. There are no more constraints regarding this protocol.

The EtherCAT master allows to create multiple VoE handlers per slave configuration via the application interface (see [chapter 3](#)). These handlers contain the state machine necessary for the communication via VoE.

For more information about using VoE handlers, see [section 3.3](#) or the example applications provided in the *examples/* subdirectory.

6.4 Servo Profile over EtherCAT (SoE)

The SoE protocol implements the Service Channel layer, specified in IEC 61800-7 [\[16\]](#) via EtherCAT mailboxes.

The SoE protocol is quite similar to the CoE protocol (see [section 6.2](#)). Instead of SDO indices and subindices, so-called identification numbers (IDNs) identify parameters.

The implementation covers the “SCC Read” and “SCC Write” primitives, each with the ability to fragment data.

There are several ways to use the SoE implementation:

- Reading and writing IDNs via the command-line tool (see [subsection 7.1.21](#)).
- Storing configurations for arbitrary IDNs via the application interface (see [chapter 3](#), i.e. `ecrt_slave_config_idn()`). These configurations are written to the slave during configuration in PREOP state, before going to SAFEOP.
- The user-space library (see [section 7.2](#)), offers functions to read/write IDNs in blocking mode (`ecrt_master_read_idn()`, `ecrt_master_write_idn()`).

7 Userspace Interfaces

For the master runs as a kernel module, accessing it is natively limited to analyzing Syslog messages and controlling using *modutils*.

It was necessary to implement further interfaces, that make it easier to access the master from userspace and allow a finer influence. It should be possible to view and to change special parameters at runtime.

Bus visualization is another point: For development and debugging purposes it is necessary to show the connected slaves with a single command, for instance (see [section 7.1](#)).

The application interface has to be available in userspace, to allow userspace programs to use EtherCAT master functionality. This was implemented via a character device and a userspace library (see [section 7.2](#)).

Another aspect is automatic startup and configuration. The master must be able to automatically start up with a persistent configuration (see [section 7.4](#)).

A last thing is monitoring EtherCAT communication. For debugging purposes, there had to be a way to analyze EtherCAT datagrams. The best way would be with a popular network analyzer, like Wireshark [8] or others (see [section 7.5](#)).

This chapter covers all these points and introduces the interfaces and tools to make all that possible.

7.1 Command-line Tool

7.1.1 Character Devices

Each master instance will get a character device as a userspace interface. The devices are named */dev/EtherCATx*, where $x \in \{0 \dots n\}$ is the index of the master.

Device Node Creation The character device nodes are automatically created, if the *udev* Package is installed. See [section 9.5](#) for how to install and configure it.

7.1.2 Setting Alias Addresses

```
ethercat alias [OPTIONS] <ALIAS>
```

Write alias addresses.

Arguments:

ALIAS must be an unsigned 16 bit number. Zero means removing an alias address.

If multiple slaves are selected, the `--force` option is required.

Command-specific options:

```
--alias      -a <alias>
--position  -p <pos>      Slave selection. See the help of
                           the 'slaves' command.
--force      -f           Acknowledge writing aliases of
                           multiple slaves.
```

Numerical values can be specified either with decimal (no prefix), octal (prefix '0') or hexadecimal (prefix '0x') base.

7.1.3 Displaying the Bus Configuration

```
ethercat config [OPTIONS]
```

Show slave configurations.

Without the `--verbose` option, slave configurations are output one-per-line. Example:

```
1001:0  0x0000003b/0x02010000  3  OP
|      |                      |  |
|      |                      |  \- Application-layer
|      |                      |    state of the attached
|      |                      |    slave, or '-', if no
|      |                      |    slave is attached.
|      |                      \- Absolute decimal ring
|      |                      position of the attached
|      |                      slave, or '-' if none
|      |                      attached.
|      \- Expected vendor ID and product code (both
|          hexadecimal).
\ - Alias address and relative position (both decimal).
```

With the `--verbose` option given, the configured PDOs and SDOs are output in addition.

Configuration selection:

Slave configurations can be selected with

the `--alias` and `--position` parameters as follows:

- 1) If neither the `--alias` nor the `--position` option is given, all slave configurations are displayed.
- 2) If only the `--position` option is given, an alias of zero is assumed (see 4)).
- 3) If only the `--alias` option is given, all slave configurations with the given alias address are displayed.
- 4) If both the `--alias` and the `--position` option are given, the selection can match a single configuration, that is displayed, if it exists.

Command-specific options:

```
--alias      -a <alias>  Configuration alias (see above).
--position   -p <pos>    Relative position (see above).
--verbose    -v          Show detailed configurations.
```

Numerical values can be specified either with decimal (no prefix), octal (prefix '0') or hexadecimal (prefix '0x') base.

7.1.4 Display CRC Error Counters

```
ethercat crc
ethercat crc reset
```

CRC error register diagnosis.

```
CRC - CRC Error Counter           0x300, 0x302, 0x304, 0x306
PHY - Physical Interface Error Counter 0x301, 0x303, 0x305, 0x307
FWD - Forwarded RX Error Counter    0x308, 0x309, 0x30a, 0x30b
NXT - Next slave
```

7.1.5 Output PDO information in C Language

```
ethercat cstruct [OPTIONS]
```

Generate slave PDO information in C language.

The output C code can be used directly with the `ecrt_slave_config_pdos()` function of the application interface.

Command-specific options:

```
--alias      -a <alias>
--position   -p <pos>    Slave selection. See the help of
                          the 'slaves' command.
```

Numerical values can be specified either with decimal (no prefix), octal (prefix '0') or hexadecimal (prefix '0x') base.

7.1.6 Displaying Process Data

`ethercat data [OPTIONS]`

Output binary domain process data.

Data of multiple domains are concatenated.

Command-specific options:

`--domain -d <index>` Positive numerical domain index.
If omitted, data of all domains
are output.

Numerical values can be specified either with decimal (no prefix), octal (prefix '0') or hexadecimal (prefix '0x') base.

7.1.7 Setting a Master's Debug Level

`ethercat debug <LEVEL>`

Set the master's debug level.

Debug messages are printed to syslog.

Arguments:

`LEVEL` can have one of the following values:
0 for no debugging output,
1 for some debug messages, or
2 for printing all frame contents (use with caution!).

Numerical values can be specified either with decimal (no prefix), octal (prefix '0') or hexadecimal (prefix '0x') base.

7.1.8 Configured Domains

`ethercat domains [OPTIONS]`

Show configured domains.

Without the `--verbose` option, the domains are displayed one-per-line. Example:

```
Domain0: LogBaseAddr 0x00000000, Size 6, WorkingCounter 0/1
```

The domain's base address for the logical datagram (LRD/LWR/LRW) is displayed followed by the domain's process data size in byte. The last values are the current datagram working counter sum and the expected working counter sum. If the values are equal, all PDOs were exchanged during the last cycle.

If the `--verbose` option is given, the participating slave configurations/FMMUs and the current process data are additionally displayed:

```
Domain1: LogBaseAddr 0x00000006, Size 6, WorkingCounter 0/1
  SlaveConfig 1001:0, SM3 ( Input), LogAddr 0x00000006, Size 6
    00 00 00 00 00 00
```

The process data are displayed as hexadecimal bytes.

Command-specific options:

```
--domain -d <index> Positive numerical domain index.
                    If omitted, all domains are
                    displayed.

--verbose -v        Show FMMUs and process data
                    in addition.
```

Numerical values can be specified either with decimal (no prefix), octal (prefix '0') or hexadecimal (prefix '0x') base.

7.1.9 SDO Access

```
ethercat download [OPTIONS] <INDEX> <SUBINDEX> <VALUE>
 [OPTIONS] <INDEX> <VALUE>
```

Write an SDO entry to a slave.

This command requires a single slave to be selected.

The data type of the SDO entry is taken from the SDO dictionary by default. It can be overridden with the `--type` option. If the slave does not support the SDO information service or the SDO is not in the dictionary, the `--type` option is mandatory.

The second call (without `<SUBINDEX>`) uses the complete access method.

These are valid data types to use with the `--type` option:

```
bool,
int8, int16, int32, int64,
uint8, uint16, uint32, uint64,
float, double,
string, octet_string, unicode_string.
```

For sign-and-magnitude coding, use the following types:

```
sm8, sm16, sm32, sm64
```

Arguments:

```
INDEX is the SDO index and must be an unsigned
```

16 bit number.
SUBINDEX is the SDO entry subindex and must be an unsigned 8 bit number.
VALUE is the value to download and must correspond to the SDO entry datatype (see above). Use '-' to read from standard input.

Command-specific options:

--alias -a <alias>
--position -p <pos> Slave selection. See the help of the 'slaves' command.
--type -t <type> SDO entry data type (see above).

Numerical values can be specified either with decimal (no prefix), octal (prefix '0') or hexadecimal (prefix '0x') base.

ethercat upload [OPTIONS] <INDEX> <SUBINDEX>

Read an SDO entry from a slave.

This command requires a single slave to be selected.

The data type of the SDO entry is taken from the SDO dictionary by default. It can be overridden with the --type option. If the slave does not support the SDO information service or the SDO is not in the dictionary, the --type option is mandatory.

These are valid data types to use with the --type option:

bool,
int8, int16, int32, int64,
uint8, uint16, uint32, uint64,
float, double,
string, octet_string, unicode_string.

For sign-and-magnitude coding, use the following types:

sm8, sm16, sm32, sm64

Arguments:

INDEX is the SDO index and must be an unsigned 16 bit number.
SUBINDEX is the SDO entry subindex and must be an unsigned 8 bit number.

Command-specific options:

--alias -a <alias>
--position -p <pos> Slave selection. See the help of the 'slaves' command.
--type -t <type> SDO entry data type (see above).

Numerical values can be specified either with decimal (no prefix), octal (prefix '0') or hexadecimal (prefix '0x') base.

7.1.10 EoE Statistics

```
ethercat eoe
```

Display Ethernet over EtherCAT statistics.

The TxRate and RxRate are displayed in Byte/s.

7.1.11 File-Access over EtherCAT

```
ethercat foe_read [OPTIONS] <SOURCEFILE>
```

Read a file from a slave via FoE.

This command requires a single slave to be selected.

Arguments:

SOURCEFILE is the name of the source file on the slave.

Command-specific options:

```
--output-file -o <file>  Local target filename. If
                          '-' (default), data are
                          printed to stdout.

--alias           -a <alias>
--position        -p <pos>  Slave selection. See the help
                          of the 'slaves' command.
```

Numerical values can be specified either with decimal (no prefix), octal (prefix '0') or hexadecimal (prefix '0x') base.

```
ethercat foe_write [OPTIONS] <FILENAME>
```

Store a file on a slave via FoE.

This command requires a single slave to be selected.

Arguments:

FILENAME can either be a path to a file, or '-'. In the latter case, data are read from stdin and the --output-file option has to be specified.

Command-specific options:

```
--output-file -o <file>  Target filename on the slave.
                          If the FILENAME argument is
                          '-', this is mandatory.
                          Otherwise, the basename() of
                          FILENAME is used by default.

--alias           -a <alias>
--position        -p <pos>  Slave selection. See the help
                          of the 'slaves' command.
```

Numerical values can be specified either with decimal (no prefix), octal (prefix '0') or hexadecimal (prefix '0x') base.

7.1.12 Creating Topology Graphs

```
ethercat graph [OPTIONS]
ethercat graph [OPTIONS] <INFO>
```

Output the bus topology as a graph.

The bus is output in DOT language (see <http://www.graphviz.org/doc/info/lang.html>), which can be processed with the tools from the Graphviz package. Example:

```
ethercat graph | dot -Tsvg > bus.svg
```

See 'man dot' for more information.

Additional information at edges and nodes is selected via the first argument:

```
DC - DC timing
CRC - CRC error register information
```

7.1.13 Setting Ethernet-over-EtherCAT IP Parameters

Slaves can have own IP stack implementations accessible via EoE. Since some of them do not provide other mechanisms to set IP parameters (because they only have an EtherCAT interface), there is a possibility to set the below parameters via EoE:

- Ethernet MAC address¹,
- IPv4 address,
- IPv4 subnet mask,
- IPv4 default gateway,
- IPv4 DNS server,
- DNS host name.

```
ethercat ip [OPTIONS] <ARGS>
```

Set EoE IP parameters.

This command requires a single slave to be selected.

IP parameters can be appended as argument pairs:

```
ip_address <IPv4>[/prefix] IP address (optionally with
```

¹The MAC address of the virtual EoE remote interface, not the one of the EtherCAT interface.

	decimal subnet prefix)
mac_address <MAC>	Link-layer address (may contain colons or hyphens)
default_gateway <IPv4>	Default gateway
dns_address <IPv4>	DNS server address
hostname <hostname>	Host name (max. 32 byte)

IPv4 addresses can be given either in dot notation or as hostnames, which will be automatically resolved.

Command-specific options:

--alias -a <alias>	
--position -p <pos>	Slave selection. See the help of the 'slaves' command.

Numerical values can be specified either with decimal (no prefix), octal (prefix '0') or hexadecimal (prefix '0x') base.

7.1.14 Master and Ethernet Devices

ethercat master [OPTIONS]

Show master and Ethernet device information.

Command-specific options:

--master -m <indices>	Master indices. A comma-separated list with ranges is supported. Example: 1,4,5,7-9. Default: - (all).
-----------------------	--

Numerical values can be specified either with decimal (no prefix), octal (prefix '0') or hexadecimal (prefix '0x') base.

7.1.15 Sync Managers, PDOs and PDO Entries

ethercat pdos [OPTIONS]

List Sync managers, PDO assignment and mapping.

For the default skin (see --skin option) the information is displayed in three layers, which are indented accordingly:

- 1) Sync managers - Contains the sync manager information from the SII: Index, physical start address, default size, control register and enable word. Example:

```
SM3: PhysAddr 0x1100, DefaultSize 0, ControlRegister 0x20, Enable
  1
```

- 2) Assigned PDOs - PDO direction, hexadecimal index and

the PDO name, if available. Note that a 'Tx' and 'Rx' are seen from the slave's point of view. Example:

```
TxPDO 0x1a00 "Channel1"
```

- 3) Mapped PDO entries - PDO entry index and subindex (both hexadecimal), the length in bit and the description, if available. Example:

```
PDO entry 0x3101:01, 8 bit, "Status"
```

Note, that the displayed PDO assignment and PDO mapping information can either originate from the SII or from the CoE communication area.

The "etherlab" skin outputs a template configuration for EtherLab's generic EtherCAT slave block.

Command-specific options:

```
--alias      -a <alias>
--position   -p <pos>      Slave selection. See the help of
                           the 'slaves' command.
--skin       -s <skin>     Choose output skin. Possible values are
                           "default" and "etherlab".
```

Numerical values can be specified either with decimal (no prefix), octal (prefix '0') or hexadecimal (prefix '0x') base.

7.1.16 Register Access

```
ethercat reg_read [OPTIONS] <ADDRESS> [SIZE]
```

Output a slave's register contents.

This command requires a single slave to be selected.

Arguments:

```
ADDRESS is the register address. Must
        be an unsigned 16 bit number.
SIZE    is the number of bytes to read and must also be
        an unsigned 16 bit number. ADDRESS plus SIZE
        may not exceed 64k. The size is ignored (and
        can be omitted), if a selected data type
        implies a size.
```

These are valid data types to use with the --type option:

```
bool,
int8, int16, int32, int64,
uint8, uint16, uint32, uint64,
float, double,
string, octet_string, unicode_string.
```

For sign-and-magnitude coding, use the following types:

sm8, sm16, sm32, sm64

Command-specific options:

```
--alias      -a <alias>
--position   -p <pos>      Slave selection. See the help of
                           the 'slaves' command.
--type       -t <type>    Data type (see above).
```

Numerical values can be specified either with decimal (no prefix), octal (prefix '0') or hexadecimal (prefix '0x') base.

```
ethercat reg_write [OPTIONS] <OFFSET> <DATA>
```

Write data to a slave's registers.

This command requires a single slave to be selected.

Arguments:

ADDRESS is the register address to write to.
 DATA depends on whether a datatype was specified with the --type option: If not, DATA must be either a path to a file with data to write, or '-', which means, that data are read from stdin. If a datatype was specified, VALUE is interpreted respective to the given type.

These are valid data types to use with the --type option:

```
bool,
int8, int16, int32, int64,
uint8, uint16, uint32, uint64,
float, double,
string, octet_string, unicode_string.
```

For sign-and-magnitude coding, use the following types:

sm8, sm16, sm32, sm64

Command-specific options:

```
--alias      -a <alias>
--position   -p <pos>      Slave selection. See the help of
                           the 'slaves' command.
--type       -t <type>    Data type (see above).
--emergency  -e           Send as emergency request.
```

Numerical values can be specified either with decimal (no prefix), octal (prefix '0') or hexadecimal (prefix '0x') base.

7.1.17 Trigger a Bus Scan

```
ethercat rescan
```

Rescan the bus.

Command a bus rescan. Gathered slave information will be forgotten and slaves will be read in again.

7.1.18 SDO Dictionary

```
ethercat sdos [OPTIONS]
```

List SDO dictionaries.

SDO dictionary information is displayed in two layers, which are indented accordingly:

1) SDOs - Hexadecimal SDO index and the name. Example:

```
SDO 0x1018, "Identity object"
```

2) SDO entries - SDO index and SDO entry subindex (both hexadecimal) followed by the access rights (see below), the data type, the length in bit, and the description. Example:

```
0x1018:01, rwrwrw, uint32, 32 bit, "Vendor id"
```

The access rights are specified for the AL states PREOP, SAFEOP and OP. An 'r' means, that the entry is readable in the corresponding state, an 'w' means writable, respectively. If a right is not granted, a dash '-' is shown.

If the --quiet option is given, only the SDOs are output.

Command-specific options:

```
--alias      -a <alias>
--position   -p <pos>      Slave selection. See the help of
                           the 'slaves' command.
--quiet      -q            Only output SDOs (without the
                           SDO entries).
```

Numerical values can be specified either with decimal (no prefix), octal (prefix '0') or hexadecimal (prefix '0x') base.

7.1.19 SII Access

It is possible to directly read or write the complete SII contents of the slaves. This was introduced for the reasons below:

- The format of the SII data is still in development and categories can be added in the future. With read and write access, the complete memory contents can be easily backed up and restored.

- Some SII data fields have to be altered (like the alias address). A quick writing must be possible for that.
- Through reading access, analyzing category data is possible from userspace.

```
ethercat sii_read [OPTIONS]
```

Output a slave's SII contents.

This command requires a single slave to be selected.

Without the `--verbose` option, binary SII contents are output.

With the `--verbose` option given, a textual representation of the data is output, that is separated by SII category names.

Command-specific options:

```
--alias      -a <alias>
--position   -p <pos>      Slave selection. See the help of
                           the 'slaves' command.
--verbose    -v           Output textual data with
                           category names.
```

Numerical values can be specified either with decimal (no prefix), octal (prefix '0') or hexadecimal (prefix '0x') base.

Reading out SII data is as easy as other commands. Though the data are in binary format, analysis is easier with a tool like *hexdump*:

```
$ ethercat sii_read --position 3 | hexdump
0000000 0103 0000 0000 0000 0000 0000 0000 008c
0000010 0002 0000 3052 07f0 0000 0000 0000 0000
0000020 0000 0000 0000 0000 0000 0000 0000 0000
...
```

Backing up SII contents can easily be done with a redirection:

```
$ ethercat sii_read --position 3 > sii-of-slave3.bin
```

To download SII contents to a slave, writing access to the master's character device is necessary (see [subsection 7.1.1](#)).

```
ethercat sii_write [OPTIONS] <FILENAME>
```

Write SII contents to a slave.

This command requires a single slave to be selected.

The file contents are checked for validity and integrity. These checks can be overridden with the `--force` option.

Arguments:

FILENAME must be a path to a file that contains a positive number of words. If it is '-', data are read from stdin.

Command-specific options:

--alias -a <alias>
--position -p <pos> Slave selection. See the help of the 'slaves' command.
--force -f Override validity checks.

Numerical values can be specified either with decimal (no prefix), octal (prefix '0') or hexadecimal (prefix '0x') base.

```
# ethercat sii_write --position 3 sii-of-slave3.bin
```

The SII contents will be checked for validity and then sent to the slave. The write operation may take a few seconds.

7.1.20 Slaves on the Bus

Slave information can be gathered with the subcommand `slaves`:

```
ethercat slaves [OPTIONS]
```

Display slaves on the bus.

If the `--verbose` option is not given, the slaves are displayed one-per-line. Example:

```
1 5555:0 PREOP + EL3162 2C. Ana. Input 0-10V
| | | | |
| | | | | \- Name from the SII if available,
| | | | | otherwise vendor ID and product
| | | | | code (both hexadecimal).
| | | | | \- Error flag. '+' means no error,
| | | | | 'E' means that scan or
| | | | | configuration failed.
| | | | | \- Current application-layer state.
| | | | | \- Decimal relative position to the last
| | | | | slave with an alias address set.
| | | | | \- Decimal alias address of this slave (if set),
| | | | | otherwise of the last slave with an alias set,
| | | | | or zero, if no alias was encountered up to this
| | | | | position.
| | | | | \- Absolute ring position in the bus.
```

If the `--verbose` option is given, a detailed (multi-line) description is output for each slave.

Slave selection:

Slaves for this and other commands can be selected with the `--alias` and `--position` parameters as follows:

- 1) If neither the `--alias` nor the `--position` option is given, all slaves are selected.
- 2) If only the `--position` option is given, it is interpreted as an absolute ring position and a slave with this position is matched.
- 3) If only the `--alias` option is given, all slaves with the given alias address and subsequent slaves before a slave with a different alias address match (use `-p0` if only the slaves with the given alias are desired, see 4)).
- 4) If both the `--alias` and the `--position` option are given, the latter is interpreted as relative position behind any slave with the given alias.

Command-specific options:

```
--alias      -a <alias>  Slave alias (see above).
--position   -p <pos>    Slave position (see above).
--verbose    -v          Show detailed slave information.
```

Numerical values can be specified either with decimal (no prefix), octal (prefix '0') or hexadecimal (prefix '0x') base.

Below is a typical output:

```
$ ethercat slaves
0      0:0  PREOP  +  EK1100 Ethernet Kopplerklemme (2A E-Bus)
1  5555:0  PREOP  +  EL3162 2K. Ana. Eingang 0-10V
2  5555:1  PREOP  +  EL4102 2K. Ana. Ausgang 0-10V
3  5555:2  PREOP  +  EL2004 4K. Dig. Ausgang 24V, 0,5A
```

7.1.21 SoE IDN Access

```
ethercat soe_read [OPTIONS] <IDN>
ethercat soe_read [OPTIONS] <DRIVE> <IDN>
```

Read an SoE IDN from a slave.

This command requires a single slave to be selected.

Arguments:

```
DRIVE      is the drive number (0 - 7). If omitted, 0 is assumed.
IDN        is the IDN and must be either an unsigned
           16 bit number acc. to IEC 61800-7-204:
           Bit 15: (0) Standard data, (1) Product data
           Bit 14 - 12: Parameter set (0 - 7)
           Bit 11 - 0: Data block number
```

or a string like 'P-0-150'.

Data of the given IDN are read and displayed according to the given datatype, or as raw hex bytes.

These are valid data types to use with the `--type` option:

```
bool,
int8, int16, int32, int64,
uint8, uint16, uint32, uint64,
float, double,
string, octet_string, unicode_string.
```

For sign-and-magnitude coding, use the following types:

```
sm8, sm16, sm32, sm64
```

Command-specific options:

```
--alias      -a <alias>
--position   -p <pos>      Slave selection. See the help of
                           the 'slaves' command.
--type       -t <type>    Data type (see above).
```

Numerical values can be specified either with decimal (no prefix), octal (prefix '0') or hexadecimal (prefix '0x') base.

```
ethercat soe_write [OPTIONS] <IDN> <VALUE>
ethercat soe_write [OPTIONS] <DRIVE> <IDN> <VALUE>
```

Write an SoE IDN to a slave.

This command requires a single slave to be selected.

Arguments:

```
DRIVE        is the drive number (0 - 7). If omitted, 0 is assumed.
IDN          is the IDN and must be either an unsigned
              16 bit number acc. to IEC 61800-7-204:
              Bit 15: (0) Standard data, (1) Product data
              Bit 14 - 12: Parameter set (0 - 7)
              Bit 11 - 0: Data block number
              or a string like 'P-0-150'.
VALUE        is the value to write (see below).
```

The VALUE argument is interpreted as the given data type (`--type` is mandatory) and written to the selected slave.

These are valid data types to use with the `--type` option:

```
bool,
int8, int16, int32, int64,
uint8, uint16, uint32, uint64,
float, double,
string, octet_string, unicode_string.
```

For sign-and-magnitude coding, use the following types:

sm8, sm16, sm32, sm64

Command-specific options:

```
--alias      -a <alias>
--position  -p <pos>      Slave selection. See the help of
                          the 'slaves' command.
--type      -t <type>    Data type (see above).
```

Numerical values can be specified either with decimal (no prefix), octal (prefix '0') or hexadecimal (prefix '0x') base.

7.1.22 Requesting Application-Layer States

```
ethercat states [OPTIONS] <STATE>
```

Request application-layer states.

Arguments:

STATE can be 'INIT', 'PREOP', 'BOOT', 'SAFEOP', or 'OP'.

Command-specific options:

```
--alias      -a <alias>
--position  -p <pos>      Slave selection. See the help of
                          the 'slaves' command.
```

Numerical values can be specified either with decimal (no prefix), octal (prefix '0') or hexadecimal (prefix '0x') base.

7.1.23 Displaying the Master Version

```
ethercat version [OPTIONS]
```

Show version information.

7.1.24 Generating Slave Description XML

```
ethercat xml [OPTIONS]
```

Generate slave information XML.

Note that the PDO information can either originate from the SII or from the CoE communication area. For slaves, that support configuring PDO assignment and mapping, the output depends on the last configuration.

Command-specific options:

```
--alias      -a <alias>
--position  -p <pos>      Slave selection. See the help of
                          the 'slaves' command.
```

Numerical values can be specified either with decimal (no prefix), octal (prefix '0') or hexadecimal (prefix '0x') base.

7.2 Userspace Library

The native application interface (see [chapter 3](#)) resides in kernelspace and hence is only accessible from inside the kernel. To make the application interface available from userspace programs, a userspace library has been created, that can be linked to programs under the terms and conditions of the LGPL, version 2 [5].

The library is named *libethercat*. Its sources reside in the *lib/* subdirectory and are build by default when using `make`. It is installed in the *lib/* path below the installation prefix as *libethercat.a* (for static linking), *libethercat.la* (for the use with *libtool*) and *libethercat.so* (for dynamic linking).

7.2.1 Using the Library

The application interface header *ecrt.h* (see [section 3.6](#)) can be used both in kernel and in user context.

The following minimal example shows how to build a program with EtherCAT functionality. An entire example can be found in the *examples/user/* path of the master sources and in [section 3.7](#).

```
#include <ecrt.h>

int main(void)
{
    ec_master_t *master = ecrt_request_master(0);

    if (!master)
        return 1; // error

    pause(); // wait for signal
    return 0;
}
```

The program can be compiled and dynamically linked to the library with the below command:

Listing 7.1: Linker command for using the userspace library

```
gcc ethercat.c -o ectest -I/opt/etherlab/include \
-L/opt/etherlab/lib -lethercat \
-Wl,--rpath -Wl,/opt/etherlab/lib
```

The library can also be linked statically to the program:

```
gcc -static ectest.c -o ectest -I/opt/etherlab/include \
    /opt/etherlab/lib/libethercat.a
```

7.2.2 Implementation

Basically the kernel API was transferred into userspace via the master character device (see [chapter 2](#), [Figure 2.1](#) and [subsection 7.1.1](#)).

The function calls of the kernel API are mapped to the userspace via an `ioctl()` interface. The userspace API functions share a set of generic `ioctl()` calls. The kernel part of the interface calls the according API functions directly, what results in a minimum additional delay (see [subsection 7.2.3](#)).

For performance reasons, the actual domain process data (see [section 2.3](#)) are not copied between kernel and user memory on every access: Instead, the data are memory-mapped to the userspace application. Once the master is configured and activated, the master module creates one process data memory area spanning all domains and maps it to userspace, so that the application can directly access the process data. As a result, there is no additional delay when accessing process data from userspace.

Kernel/User API Differences Because of the memory-mapping of the process data, the memory is managed internally by the library functions. As a result, it is not possible to provide external memory for domains, like in the kernel API. The corresponding functions are only available in kernelspace. This is the only difference when using the application interface in userspace.

7.2.3 Timing

An interesting aspect is the timing of the userspace library calls compared to those of the kernel API. [Table 7.1](#) shows the call times and standard deviancies of typical (and time-critical) API functions measured on an Intel Pentium 4 M CPU with 2.2 GHz and a standard 2.6.26 kernel.

Table 7.1: Application Interface Timing Comparison

Function	Kernelspace		Userspace	
	$\mu(t)$	$\sigma(t)$	$\mu(t)$	$\sigma(t)$
<code>ecrt_master_receive()</code>	1.1 μs	0.3 μs	2.2 μs	0.5 μs
<code>ecrt_domain_process()</code>	< 0.1 μs	< 0.1 μs	1.0 μs	0.2 μs
<code>ecrt_domain_queue()</code>	< 0.1 μs	< 0.1 μs	1.0 μs	0.1 μs
<code>ecrt_master_send()</code>	1.8 μs	0.2 μs	2.5 μs	0.5 μs

The test results show, that for this configuration, the userspace API causes about 1 μs additional delay for each function, compared to the kernel API.

7.3 RTDM Interface

When using the userspace interfaces of realtime extensions like Xenomai or RTAI, the use of *ioctl()* is not recommended, because it may disturb realtime operation. To accomplish this, the Real-Time Device Model (RTDM) [17] has been developed. The master module provides an RTDM interface (see [Figure 2.1](#)) in addition to the normal character device, if the master sources were configured with `--enable-rtdm` (see [chapter 9](#)).

To force an application to use the RTDM interface instead of the normal character device, it has to be linked with the *libethercat_rtdm* library instead of *libethercat*. The use of the *libethercat_rtdm* is transparent, so the EtherCAT header *ecrt.h* (see [section 3.6](#)) with the complete API can be used as usual.

To make the example in [Listing 7.1](#) use the RTDM library, the linker command has to be altered as follows:

```
gcc ethercat-with-rtdm.c -o ectest -I/opt/etherlab/include \
    -L/opt/etherlab/lib -lethercat_rtdm \
    -Wl,--rpath -Wl,/opt/etherlab/lib
```

7.4 System Integration

To integrate the EtherCAT master as a service into a running system, it comes with an init script and a sysconfig file, that are described below. Modern systems may be managed by systemd [7]. Integration of the master with systemd is described in [subsection 7.4.4](#).

7.4.1 Init Script

The EtherCAT master init script conforms to the requirements of the “Linux Standard Base” (LSB, [6]). The script is installed to *etc/init.d/ethercat* below the installation prefix and has to be copied (or better: linked) to the appropriate location (see [chapter 9](#)), before the master can be inserted as a service. Please note, that the init script depends on the sysconfig file described below.

To provide service dependencies (i. e. which services have to be started before others) inside the init script code, LSB defines a special comment block. System tools can extract this information to insert the EtherCAT init script at the correct place in the startup sequence:

```
# Description:          EtherCAT master 1.6.0
### END INIT INFO
```

```
#-----

LSMOD=/sbin/lsmmod
MODPROBE=/sbin/modprobe
RMMOD=/sbin/rmmod
MODINFO=/sbin/modinfo
ETHERCAT=/usr/local/bin/ethercat
MASTER_ARGS=
```

7.4.2 Sysconfig File

For persistent configuration, the init script uses a sysconfig file installed to *etc/sysconfig/ethercat* (below the installation prefix), that is mandatory for the init script. The sysconfig file contains all configuration variables needed to operate one or more masters. The documentation is inside the file and included below:

```
1 #
2 # Main Ethernet devices.
3 #
4 # The MASTER<X>_DEVICE variable specifies the Ethernet device for a master
5 # with index 'X'.
6 #
7 # Specify the MAC address (hexadecimal with colons) of the Ethernet device to
8 # use. Example: "00:00:08:44:ab:66"
9 #
10 # The broadcast address "ff:ff:ff:ff:ff:ff" has a special meaning: It tells
11 # the master to accept the first device offered by any Ethernet driver.
12 #
13 # The MASTER<X>_DEVICE variables also determine, how many masters will be
14 # created: A non-empty variable MASTER0_DEVICE will create one master, adding a
15 # non-empty variable MASTER1_DEVICE will create a second master, and so on.
16 #
17 MASTER0_DEVICE=""
18 #MASTER1_DEVICE=""
19 #
20 #
21 # Backup Ethernet devices
22 #
23 # The MASTER<X>_BACKUP variables specify the devices used for redundancy. They
24 # behaves nearly the same as the MASTER<X>_DEVICE variable, except that it
25 # does not interpret the ff:ff:ff:ff:ff:ff address.
26 #
27 #MASTER0_BACKUP=""
28 #
29 #
30 # Ethernet driver modules to use for EtherCAT operation.
31 #
32 # Specify a non-empty list of Ethernet drivers, that shall be used for
33 # EtherCAT operation.
34 #
35 # Except for the generic Ethernet driver module, the init script will try to
36 # unload the usual Ethernet driver modules in the list and replace them with
37 # the EtherCAT-capable ones. If a certain (EtherCAT-capable) driver is not
38 # found, a warning will appear.
39 #
40 # Possible values: 8139too, e100, e1000, e1000e, r8169, generic, ccat, igb.
41 # Separate multiple drivers with spaces.
```

```
42 #
43 # Note: The e100, e1000, e1000e, r8169, ccat and igb drivers are not built by
44 # default. Enable them with the --enable-<driver> configure switches.
45 #
46 # Attention: When using the generic driver, the corresponding Ethernet device
47 # has to be activated (with OS methods, for example 'ip link set ethX up'),
48 # before the master is started, otherwise all frames will time out.
49 #
50 DEVICE_MODULES=""
51
52 #
53 # Flags for loading kernel modules.
54 #
55 # This can usually be left empty. Adjust this variable, if you have problems
56 # with module loading.
57 #
58 #MODPROBE_FLAGS="-b"
59
60 #-----
```

For systems managed by `systemd` (see [subsection 7.4.4](#)), the `sysconfig` file has moved to `/etc/ethercat.conf`. Both versions are part of the master sources and are meant to be used alternatively.

7.4.3 Starting the Master as a Service

After the `init` script and the `sysconfig` file are placed into the right location, the EtherCAT master can be inserted as a service. The different Linux distributions offer different ways to mark a service for starting and stopping in certain runlevels. For example, SUSE Linux provides the `insserv` command:

```
# insserv ethercat
```

The `init` script can also be used for manually starting and stopping the EtherCAT master. It has to be executed with one of the parameters `start`, `stop`, `restart` or `status`.

```
# /etc/init.d/ethercat restart
Shutting down EtherCAT master           done
Starting EtherCAT master                 done
```

7.4.4 Integration with `systemd`

Distributions using `systemd` instead of the SysV `init` system are using service files to describe how a service is to be maintained. [Listing 7.2](#) lists the master's service file:

Listing 7.2: Service file

```
#
# EtherCAT master kernel modules
#
```

```

[Unit]
Description=EtherCAT Master Kernel Modules

# Fine tuning of the startup dependencies below are recommended
# to provide a reliable startup routine.
# The dependencies below can be either uncommented after copying
# this file to /etc/systemd/system or by creating overrides:
# Copy the needed dependencies into
# /etc/systemd/system/ethercat.service.d/50-dependencies.conf
# in a [Unit] section.

#
# Uncomment this, if the generic Ethernet driver is used. It assures,
#   that the
# network interfaces are configured, before the master starts.
#
#Requires=network.target # Stop master, if network is stopped
#After=network.target # Start master, after network is ready

#
# Uncomment this, if a native Ethernet driver is used. It assures,
#   that the
# network interfaces are configured, after the Ethernet drivers have
#   been
# replaced. Otherwise, the networking configuration tools could be
#   confused.
#
#Before=network-pre.target
#Wants=network-pre.target

[Service]
Type=oneshot
RemainAfterExit=yes
ExecStart=/usr/local/sbin/ethercatctl start
ExecStop=/usr/local/sbin/ethercatctl stop

[Install]
WantedBy=multi-user.target

```

The *ethercatctl* command is used to load and unload the master and network driver modules in a similar way to the former init script ([subsection 7.4.1](#)). Because it is installed into the *sbin/* directory, it can also be used separately:

```
# ethercatctl start
```

When using systemd and/or the *ethercatctl* command, the master configuration must be in */etc/ethercat.conf* instead of */etc/sysconfig/ethercat!* The latter is ignored. The configuration options are exactly the same.

7.5 Debug Interfaces

EtherCAT buses can always be monitored by inserting a switch between master and slaves. This allows to connect another PC with a network monitor like Wireshark [8], for example. It is also possible to listen to local network interfaces on the machine running the EtherCAT master directly. If the generic Ethernet driver (see [section 4.3](#)) is used, the network monitor can directly listen on the network interface connected to the EtherCAT bus.

When using native Ethernet drivers (see [section 4.2](#)), there are no local network interfaces to listen to, because the Ethernet devices used for EtherCAT are not registered at the network stack. For that case, so-called “debug interfaces” are supported, which are virtual network interfaces allowing to capture EtherCAT traffic with a network monitor (like Wireshark or tcpdump) running on the master machine without using external hardware. To use this functionality, the master sources have to be configured with the `--enable-debug-if` switch (see [chapter 9](#)).

Every EtherCAT master registers a read-only network interface per attached physical Ethernet device. The network interfaces are named `ecdbgmX` for the main device, and `ecdbgbX` for the backup device, where X is the master index. The below listing shows a debug interface among some standard network interfaces:

```
# ip link
1: lo: <LOOPBACK,UP> mtu 16436 qdisc noqueue
   link/loopback 00:00:00:00:00:00 brd 00:00:00:00:00:00
4: eth0: <BROADCAST,MULTICAST> mtu 1500 qdisc noop qlen 1000
   link/ether 00:13:46:3b:ad:d7 brd ff:ff:ff:ff:ff:ff
8: ecdbgm0: <BROADCAST,MULTICAST> mtu 1500 qdisc pfifo_fast
   qlen 1000
   link/ether 00:04:61:03:d1:01 brd ff:ff:ff:ff:ff:ff
```

While a debug interface is enabled, all frames sent or received to or from the physical device are additionally forwarded to the debug interface by the corresponding master. Network interfaces can be enabled with the below command:

```
# ip link set dev ecdbgm0 up
```

Please note, that the frame rate can be very high. With an application connected, the debug interface can produce thousands of frames per second.

Attention The socket buffers needed for the operation of debug interfaces have to be allocated dynamically. Some Linux realtime extensions (like RTAI) do not allow this in realtime context!

8 Timing Aspects

Although EtherCAT's timing is highly deterministic and therefore timing issues are rare, there are a few aspects that can (and should be) dealt with.

8.1 Application Interface Profiling

One of the most important timing aspects are the execution times of the application interface functions, that are called in cyclic context. These functions make up an important part of the overall timing of the application. To measure the timing of the functions, the following code was used:

```
c0 = get_cycles();
ecrt_master_receive(master);
c1 = get_cycles();
ecrt_domain_process(domain1);
c2 = get_cycles();
ecrt_master_run(master);
c3 = get_cycles();
ecrt_master_send(master);
c4 = get_cycles();
```

Between each call of an interface function, the CPU timestamp counter is read. The counter differences are converted to μs with help of the `cpu_khz` variable, that contains the number of increments per ms.

For the actual measuring, a system with a 2.0 GHz CPU was used, that ran the above code in an RTAI thread with a period of 100 μs . The measuring was repeated $n = 100$ times and the results were averaged. These can be seen in [Table 8.1](#).

Table 8.1: Profiling of an Application Cycle on a 2.0 GHz Processor

Element	Mean Duration [s]	Standard Deviancy [μs]
<i>ecrt_master_receive()</i>	8.04	0.48
<i>ecrt_domain_process()</i>	0.14	0.03
<i>ecrt_master_run()</i>	0.29	0.12
<i>ecrt_master_send()</i>	2.18	0.17
Complete Cycle	10.65	0.69

It is obvious, that the functions accessing hardware make up the lion's share. The *ec_master_receive()* executes the ISR of the Ethernet device, analyzes datagrams and copies their contents into the memory of the datagram objects. The *ec_master_send()* assembles a frame out of different datagrams and copies it to the hardware buffers. Interestingly, this makes up only a quarter of the receiving time.

The functions that only operate on the masters internal data structures are very fast ($\Delta t < 1 \mu\text{s}$). Interestingly the runtime of *ec_domain_process()* has a small standard deviancy relative to the mean value, while this ratio is about twice as big for *ec_master_run()*: This probably results from the latter function having to execute code depending on the current state and the different state functions are more or less complex.

For a realtime cycle makes up about $10 \mu\text{s}$, the theoretical frequency can be up to 100 kHz. For two reasons, this frequency keeps being theoretical:

1. The processor must still be able to run the operating system between the realtime cycles.
2. The EtherCAT frame must be sent and received, before the next realtime cycle begins. The determination of the bus cycle time is difficult and covered in [section 8.2](#).

8.2 Bus Cycle Measuring

For measuring the time, a frame is “on the wire”, two timestamps must be taken:

1. The time, the Ethernet hardware begins with physically sending the frame.
2. The time, the frame is completely received by the Ethernet hardware.

Both times are difficult to determine. The first reason is, that the interrupts are disabled and the master is not notified, when a frame is sent or received (polling would distort the results). The second reason is, that even with interrupts enabled, the time from the event to the notification is unknown. Therefore the only way to confidently determine the bus cycle time is an electrical measuring.

Anyway, the bus cycle time is an important factor when designing realtime code, because it limits the maximum frequency for the cyclic task of the application. In practice, these timing parameters are highly dependent on the hardware and often a trial and error method must be used to determine the limits of the system.

The central question is: What happens, if the cycle frequency is too high? The answer is, that the EtherCAT frames that have been sent at the end of the cycle are not yet received, when the next cycle starts. First this is noticed by *ecrt_domain_process()*, because the working counter of the process data datagrams were not increased. The function will notify the user via Syslog¹. In this case, the process data keeps being the

¹To limit Syslog output, a mechanism has been implemented, that outputs a summarized notification at maximum once a second.

same as in the last cycle, because it is not erased by the domain. When the domain datagrams are queued again, the master notices, that they are already queued (and marked as sent). The master will mark them as unsent again and output a warning, that datagrams were “skipped”.

On the mentioned 2.0 GHz system, the possible cycle frequency can be up to 25 kHz without skipped frames. This value can surely be increased by choosing faster hardware. Especially the RealTek network hardware could be replaced by a faster one. Besides, implementing a dedicated ISR for EtherCAT devices would also contribute to increasing the latency. These are two points on the author’s to-do list.

9 Installation

9.1 Getting the Software

There are several ways to get the master software:

1. An official release (for example 1.6.0), can be downloaded from the master's website¹ at the EtherLab project [1] as a tarball.
2. The most recent development revision (and moreover any other revision) can be obtained via the Git [14] repository on the master's project page on GitLab.com². The whole repository can be cloned with the command

```
git clone https://gitlab.com/etherlab.org/ethercat.git
    local-dir
```

3. Without a local Git installation, tarballs of arbitrary revisions can be downloaded via the “Download” button on GitLab.

9.2 Building the Software

After downloading a tarball or cloning the repository as described in section 9.1, the sources have to be prepared and configured for the build process.

When a tarball was downloaded, it has to be extracted with the following commands:

```
$ tar xjf ethercat-1.6.0.tar.bz2
$ cd ethercat-1.6.0/
```

The software configuration is managed with Autoconf [15] so the released versions contain a `configure` shell script, that has to be executed for configuration (see below).

Bootstrap When downloading or cloning directly from the repository, the `configure` script does not yet exist. It can be created via the `bootstrap.sh` script in the master sources. The autoconf and automake packages are required for this.

¹<https://etherlab.org/ethercat>

²<https://gitlab.com/etherlab.org/ethercat>

Configuration and Build The configuration and the build process follow the below commands:

```
$ ./configure
$ make
$ make modules
```

Table 9.1 lists important configuration switches and options.

Table 9.1: Configuration options

Option/Switch	Description	Default
<code>--prefix</code>	Installation prefix	<code>/opt/etherlab</code>
<code>--with-linux-dir</code>	Linux kernel sources	Use running kernel
<code>--with-module-dir</code>	Subdirectory in the kernel module tree, where the EtherCAT kernel modules shall be installed.	<code>ethercat</code>
<code>--enable-generic</code>	Build the generic Ethernet driver (see section 4.3).	yes
<code>--enable-8139too</code>	Build the 8139too driver	yes
<code>--with-8139too-kernel</code>	8139too kernel	†
<code>--enable-e100</code>	Build the e100 driver	no
<code>--with-e100-kernel</code>	e100 kernel	†
<code>--enable-e1000</code>	Enable e1000 driver	no
<code>--with-e1000-kernel</code>	e1000 kernel	†
<code>--enable-e1000e</code>	Enable e1000e driver	no
<code>--with-e1000e-kernel</code>	e1000e kernel	†
<code>--enable-r8169</code>	Enable r8169 driver	no
<code>--with-r8169-kernel</code>	r8169 kernel	†
<code>--enable-ccat</code>	Enable ccat driver (independent of kernel version)	no
<code>--enable-igb</code>	Enable igb driver	no
<code>--with-igb-kernel</code>	igb kernel	†
<code>--enable-kernel</code>	Build the master kernel modules	yes
<code>--enable-rtm</code>	Create the RTDM interface (RTAI or Xenomai directory needed, see below)	no
<code>--with-rtai-dir</code>	RTAI path (for RTAI examples and RTDM interface)	
<code>--with-xenomai-dir</code>	Xenomai path (for Xenomai examples and RTDM interface)	
<code>--with-devices</code>	Number of Ethernet devices for redundant operation (> 1 switches redundancy on)	1

Option/Switch	Description	Default
<code>--with-systemdsystemunitdir</code>	Systemd unit directory (“no” disables service file installation)	auto
<code>--enable-debug-if</code>	Create a debug interface for each master	no
<code>--enable-debug-ring</code>	Create a debug ring to record frames	no
<code>--enable-eoe</code>	Enable EoE support	yes
<code>--enable-cycles</code>	Use CPU timestamp counter. Enable this on Intel architecture to get finer timing calculation.	no
<code>--enable-hrtimer</code>	Use high-resolution timer to let the master state machine sleep between sending frames.	no
<code>--enable-regalias</code>	Read alias address from register	no
<code>--enable-tool</code>	Build the command-line tool “ethercat” (see section 7.1)	yes
<code>--enable-userlib</code>	Build the userspace library	yes
<code>--enable-tty</code>	Build the TTY driver	no
<code>--enable-wildcards</code>	Enable <code>0xffffffff</code> to be wildcards for vendor ID and product code	no
<code>--enable-sii-assign</code>	Enable assigning SII access to the PDI layer during slave configuration	no
<code>--enable-rt-syslog</code>	Enable syslog statements in real-time context	yes

† If this option is not specified, the kernel version to use is extracted from the Linux kernel sources.

9.3 Building the Interface Documentation

The source code is documented using Doxygen [13]. To build the HTML documentation, the Doxygen software has to be installed. The below command will generate the documents in the subdirectory *doxygen-output*:

```
$ make doc
```

The interface documentation can be viewed by pointing a browser to the file *doxygen-output/html/index.html*. The functions and data structures of the application interface are covered by an own module “Application Interface”.

9.4 Installing the Software

The below commands have to be entered as *root*: The first one will install the EtherCAT header, init script, sysconfig file and the userspace tool to the prefix path. The second one will install the kernel modules to the kernel's modules directory. The final `depmod` call is necessary to include the kernel modules into the `modules.dep` file to make it available to the `modprobe` command, used in the init script.

```
# make install
# make modules_install
```

If the target kernel's modules directory is not under `/lib/modules`, a different destination directory can be specified with the `DESTDIR` make variable. For example:

```
# make DESTDIR=/vol/nfs/root modules_install
```

This command will install the compiled kernel modules to `/vol/nfs/root/lib/modules`, prepended by the kernel release.

If the EtherCAT master shall be run as a service³ (see [section 7.4](#)), the init script and the sysconfig file (or the systemd service file, respectively) have to be copied (or linked) to the appropriate locations. The below example is suitable for SUSE Linux. It may vary for other distributions.

```
# cd /opt/etherlab
# cp etc/sysconfig/ethercat /etc/sysconfig/
# ln -s etc/init.d/ethercat /etc/init.d/
# inserv ethercat
```

Now the sysconfig file `/etc/sysconfig/ethercat` (see [subsection 7.4.2](#)), or the configuration file `/etc/ethercat.conf`, if using systemd, has to be customized. The minimal customization is to set the `MASTER0_DEVICE` variable to the MAC address of the Ethernet device to use (or `ff:ff:ff:ff:ff:ff` to use the first device offered) and selecting the driver(s) to load via the `DEVICE_MODULES` variable.

After the basic configuration is done, the master can be started with the below command:

```
# /etc/init.d/ethercat start
```

When using systemd, the following command can be used alternatively:

```
# ethercatctl start
```

At this time, the operation of the master can be observed by viewing the Syslog messages, which should look like the ones below. If EtherCAT slaves are connected to the master's EtherCAT device, the activity indicators should begin to flash.

³Even if the EtherCAT master shall not be loaded on system startup, the use of the init script is recommended for manual (un-)loading.

```

1 EtherCAT: Master driver 1.6.0
2 EtherCAT: 1 master waiting for devices.
3 EtherCAT Intel(R) PRO/1000 Network Driver - version 6.0.60-k2
4 Copyright (c) 1999-2005 Intel Corporation.
5 PCI: Found IRQ 12 for device 0000:01:01.0
6 PCI: Sharing IRQ 12 with 0000:00:1d.2
7 PCI: Sharing IRQ 12 with 0000:00:1f.1
8 EtherCAT: Accepting device 00:0E:0C:DA:A2:20 for master 0.
9 EtherCAT: Starting master thread.
10 ec_e1000: ec0: e1000_probe: Intel(R) PRO/1000 Network
11      Connection
12 ec_e1000: ec0: e1000_watchdog_task: NIC Link is Up 100 Mbps
13      Full Duplex
14 EtherCAT: Link state changed to UP.
15 EtherCAT: 7 slave(s) responding.
16 EtherCAT: Slave states: PREOP.
17 EtherCAT: Scanning bus.
18 EtherCAT: Bus scanning completed in 431 ms.

```

- ① – ② The master module is loading, and one master is initialized.
- ③ – ⑧ The EtherCAT-capable e1000 driver is loading. The master accepts the device with the address 00:0E:0C:DA:A2:20.
- ⑨ – ⑯ The master goes to idle phase, starts its state machine and begins scanning the bus.

9.5 Automatic Device Node Creation

The `ethercat` command-line tool (see [section 7.1](#)) communicates with the master via a character device. The corresponding device nodes are created automatically, if the `udev` daemon is running. Note, that on some distributions, the `udev` package is not installed by default.

The device nodes will be created with mode `0660` and group `root` by default. If “normal” users shall have reading access, a `udev` rule file (for example `/etc/udev/rules.d/99-EtherCAT.rules`) has to be created with the following contents:

```
KERNEL=="EtherCAT[0-9]*", MODE="0664"
```

After the `udev` rule file is created and the EtherCAT master is restarted with `/etc/init.d/ethercat restart`, the device node will be automatically created with the desired rights:

```
# ls -l /dev/EtherCAT0
crw-rw-r-- 1 root root 252, 0 2008-09-03 16:19 /dev/EtherCAT0
```

Now, the `ethercat` tool can be used (see [section 7.1](#)) even as a non-root user.

If non-root users shall have writing access, the following udev rule can be used instead:

```
KERNEL=="EtherCAT[0-9]*", MODE="0664", GROUP="users"
```

Bibliography

- [1] Ingenieurgesellschaft IgH: EtherLab – Open Source Toolkit for rapid realtime code generation under Linux with Simulink/RTW and EtherCAT technology. <https://etherlab.org>, 2024.
- [2] IEC 61158-4-12: Data-link Protocol Specification. International Electrotechnical Commission (IEC), 2005.
- [3] IEC 61158-6-12: Application Layer Protocol Specification. International Electrotechnical Commission (IEC), 2005.
- [4] GNU General Public License, Version 2. <http://www.gnu.org/licenses/gpl-2.0.html>. October 15, 2008.
- [5] GNU Lesser General Public License, Version 2.1. <http://www.gnu.org/licenses/old-licenses/lgpl-2.1.html>. October 15, 2008.
- [6] Linux Standard Base. <http://www.linuxfoundation.org/en/LSB>. August 9, 2006.
- [7] systemd System and Service Manager <http://freedesktop.org/wiki/Software/systemd>. January 18, 2013.
- [8] Wireshark. <http://www.wireshark.org>. 2008.
- [9] *Hopcroft, J. E. / Ullman, J. D.*: Introduction to Automata Theory, Languages and Computation. Adison-Wesley, Reading, Mass. 1979.
- [10] *Wagner, F. / Wolstenholme, P.*: State machine misunderstandings. In: IEE journal “Computing and Control Engineering”, 2004.
- [11] RTAI. The RealTime Application Interface for Linux from DIAPM. <https://www.rtai.org>, 2010.
- [12] RT PREEMPT HOWTO. http://rt.wiki.kernel.org/index.php/RT_PREEMPT_HOWTO, 2010.
- [13] Doxygen. Source code documentation generator tool. <http://www.stack.nl/~dimitri/doxygen>, 2008.
- [14] Git SCM. <https://git-scm.com>, 2021.
- [15] Autoconf – GNU Project – Free Software Foundation (FSF). <http://www.gnu.org/software/autoconf>, 2010.
- [16] IEC 61800-7-304: Adjustable speed electrical power drive systems - Part 7-300: Generic interface and use of profiles for power drive systems - Mapping of profiles to network technologies. International Electrotechnical Commission (IEC), 2007.
- [17] *J. Kiszka*: The Real-Time Driver Model and First Applications. <http://svn.gna.org/svn/xenomai/tags/v2.4.0/doc/nodist/pdf/RTDM-and-Applications.pdf>, 2013.

Glossary

ADEOS Adaptive Domain Environment for Operating Systems, page 1

CoE CANopen over EtherCAT, Mailbox Protocol, page 107

ecdev EtherCAT Device, page 83

EoE Ethernet over EtherCAT, Mailbox Protocol, page 103

FSM Finite State Machine, page 85

ISR Interrupt Service Routine, page 78

LSB Linux Standard Base, page 3

PCI Peripheral Component Interconnect, Computer Bus, page 80

RTAI Realtime Application Interface, page 1

Index

- Application, [5](#)
- Application Interface, [22](#)
- Application interface, [13](#)
- Bus cycle, [136](#)
- CoE, [107](#)
- Concurrency, [17](#)
- Debug Interfaces, [134](#)
- Device interface, [83](#)
- Device modules, [5](#)
- Distributed Clocks, [19](#)
- Domain, [9](#)
- EoE, [103](#)
- Example Applications, [13](#)
- FMMU
 - Configuration, [11](#)
- FSM, [85](#)
 - EoE, [104](#)
 - Master, [91](#)
 - PDO, [98](#)
 - SII, [97](#)
 - Slave Configuration, [94](#)
 - Slave Scan, [91](#)
 - State Change, [96](#)
 - Theory, [86](#)
- GPL, [3](#)
- Idle phase, [9](#)
- Init script, [7](#), [130](#)
- Interrupt, [78](#), [79](#)
- ISR, [78](#)
- LGPL, [3](#)
- LSB, [130](#)
- MAC address, [7](#)
- Mailbox, [103](#)
- Master
 - Architecture, [5](#)
 - Features, [1](#)
 - Installation, [139](#)
- Master Module, [5](#)
- Master module, [7](#)
- Master phases, [9](#)
- net_device, [78](#)
- netif, [79](#)
- Network drivers, [77](#), [84](#)
- Operation phase, [9](#)
- Orphaned phase, [9](#)
- PDO, [9](#)
- Process data, [9](#)
- Profiling, [135](#)
- Redundancy, [83](#)
- Service, [132](#)
- SII, [97](#), [104](#)
 - Access, [122](#)
- Socket buffer, [78](#), [79](#)
- SoE, [109](#)
- Sysconfig file, [131](#)
- Syslog, [142](#)
- systemd, [132](#)
- Userspace, [111](#)
- VoE, [109](#)